



The fastest non-contact
Jet Valve dispensing system

CONTENTS

	Pages
1. SAFETY	4-5
2. UNPACKING AND INSPECTION	6-7
3. TS9800 PIEZO JET VALVE DESCRIPTION	8
4. SETUP INSTRUCTIONS	
4.1 Mounting & Connection	9-10
4.2 Setup	10-13
4.3 Nozzle Calibration	14-16
5. OPERATION	
5.1 Start Dispensing	17
5.2 Parameter Settings	17-19
6. HEATING	
6.1 Introduction	20
6.2 Safety Instructions	20
6.3 Function	20
6.4 Mounting & Connection	21
6.5 Setup	22-23
7. VALVE REMOVAL AND CLEANING	
7.1 Valve Removal.....	24
7.2 Installation of New Nozzle Insert	24-25
7.3 Cleaning	25-37
8. TS9800 PIEZO JET VALVE	
8.1 Valve Modules	38-39
8.2 Technical Specifications	39
8.3 Special Features	39-40
8.4 Materials Applied	40
9. TS980 JET VALVE CONTROLLER	
9.1 Description	41
9.2 Technical Specifications	41
9.3 Features	42

9.4	Symbol Definitions	43
9.5	Operation	
9.5.1	Login	44
9.5.2	Disable Password Protection.....	44
9.5.3	Enable Password Protection	45
9.5.4	Resetting Master Password	45-46
9.5.5	Setup Dispensing Parameters	46-48
9.5.6	Calling Up Dispense Parameters.....	48
9.5.7	Reset Cycle Counter	49
9.5.8	To Run Dot or Line Mode	49-50
9.5.9	Service Mode	50
9.5.10	IoT (Remote Communication)	50-52
9.5.11	Software Update	52
10.	SPARE PARTS AND SCHEMATICS	
10.1	Tappets & Nozzle Inserts	53
10.2	Tools	53
10.3	Piezo Jet Valve Parts List	54-55
10.4	DB-15 I/O Port	56
10.5	Serial Port	57
11.	TROUBLESHOOTING	
11.1	General Problems.....	58
11.2	Key Variables	59
11.3	Nozzle Selection	59
11.4	Sample Parameters	60-62
12.	WARRANTY AND RETURN	
12.1	Warranty.....	63
12.2	Return.....	64

1. SAFETY

1.1 Intended Use

OK International cannot be responsible for injuries or damages resulting from unintended applications of its equipment. Unintended uses may result from taking the following actions:

- Making changes to equipment that has not been recommended in the User Guide.
- Using incompatible or damaged replacement parts.
- Using unapproved accessories or auxiliary equipment.

1.2 Safety Precautions

- Do not operate this unit in excess of maximum ratings/settings.
- Always wear appropriate personal protective clothing or apparel.
- This equipment is for indoor use only.

1.3 Specified Normal Operation

- The TS9800 System can be used for dispensing fluids with a wide range of fluid viscosity.
- Additional heating may only be carried out with a heating system from Techcon.
- The usage of the TS9800 System can be carried out under laboratorial or production environments.
- Provided the highest frequencies (up to 1500 Hz; average frequency should not exceed 800 Hz) and parameter settings must be followed.
- The usage of media which affects the functioning of the TS9800 System must be avoided.

1.4 Technical Details

- The usage of the TS9800 System is only allowed inside and up to 2,000 meters above sea level.
- Relative humidity: maximum 80% at 31 °C, decreasing linear until 50% at 50 °C.
- Fluctuation of the line voltage is not allowed over $\pm 10\%$ of the nominal voltage.
- Transient over voltage according to IEC 60364-4-443 will be tolerated: degree of pollution 2 is allowed.
- The employed power cords must be accompanied by an earthing equipment conductor. The used power sockets must be within safety regulations. When using cables which are not supplied by OK International, the warranty of the TS9800 System will only range till the operator interface.
- During installation and operation, please be sure to supply enough air circulation: minimum distance above and below the system (valve and control unit) are 1.5 cm. OK International advises a separate housing which is in alignment of fire prevention covering EN 61010-1.

- When using the TS9800 Piezo Jet Valve with heater, please note that the tangible surfaces can be hot, which can lead to severe burns.
- The safety by the apparatus can be affected by using parts/units not advised by OK International. The same can be considered for the usage of dangerous substances or operation in an explosive environment, for which the TS9800 System is not designed.

1.5 Warning Notices

- Never use the valve without the nozzle insert or without fluid.
- Never disconnect the cables during the dispensing process.
- Avoid fast turning on and off of the control unit.
- Avoid long stand-by durations while the system is switched on.
- The TS9800 System is constructed modularly. If a defect occurs, the effected module should not be interchanged with other parts. The whole system needs to be sent back to Techcon for repair. The cables can stay with the customer but need to be checked. Information on how to check the performance is available from Techcon.
- Avoid hard placing of the valve on the working surfaces during mounting and dismounting.
- Store the valve on a flat surface during the cleaning procedures. Do not shake or bang the valve on any hard surface.
- For cleaning the valve, use a damp (isopropanol) cloth and make sure that no fluid leaks into the valve (e. g. via connectors).
- Never connect the TS9800 Piezo Jet Valve to a control unit other than the TS980 (connecting it to another control system will damage the valve).
- Check whether all fluid connections are attached and sealed.
- Make sure all fluid contacting parts are stable against the fluid.
- Make sure all electronic connections are connected and interlocked.
- Make sure the supply pressure does not exceed the admissible range.
- Make sure the maximum possible system pressure ranges between the valve limit and the connection supplies limit - in no case above it.
- Check before the use of a heating device that the fluid does not tend toward unwanted reactions at elevated temperatures.
- When using a heating device, make sure the set temperature does not exceed the recommended temperature of the material (consult with the material manufacture).
- When using a heating device, please pay attention to the syringe/cartridge feeding pressure.
- The heating of the TS9800 System cannot exceed 90°C.
- **Caution:** The TS9800 Piezo Jet Valve works with the normally open concept. Therefore, without supply voltage, the valve will open, and the fluid may leak. To avoid leakage, disconnect the air supply to the fluid syringe before shutting down the control unit.

2. UNPACKING AND INSPECTION

Carefully unpack the valve and examine the items contained in the carton.

Piezo Jet Valve Package Includes:

- 1) TS9800 Piezo Jet Valve
- 2) Syringe Bracket with M4 holding screw
- 3) Nozzle installation tool
- 4) Nozzle adjustment tool
- 5) Tappet changing tool
- 6) Tappet seal tool
- 7) Heater Cable, 2M (4-pin connectors) **Available only if the piezo jet valve with heating system was ordered*
- 8) Heat Guard Kit with M6 holding screw **Available only if the piezo jet valve with heating system was ordered*
- 9) User Guide (not pictured)

**Heater and Nozzle Insert are sold separately*

Inspect the unit for any damage which may have occurred in transit. If such damage has occurred, notify the carrier at once. Claims for damage must be made by the consignee to the carrier and should be reported to the manufacturer.

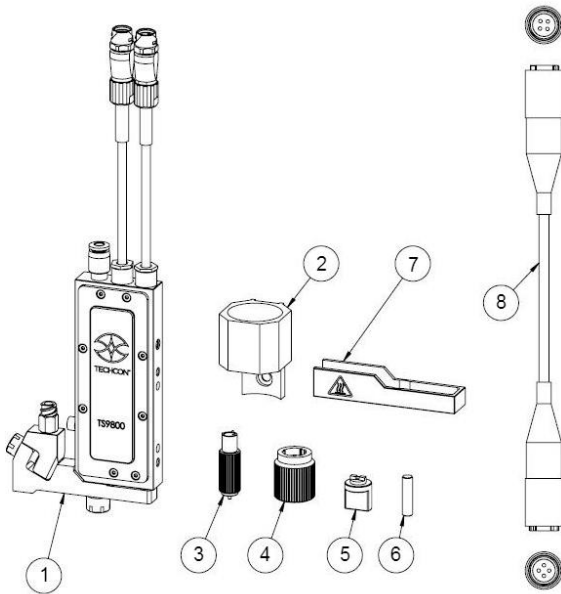

Figure 1A: TS9800 Piezo Jet Valve

Controller Package Includes (*sold separately*):

- 1) Jet Valve Smart Controller TS980
- 2) Sensor Cable, 2M (6-to-5 pin connectors)
- 3) Actuator Cable, 2M (3-to-2 pin connectors)
- 4) Power Supply (not pictured)

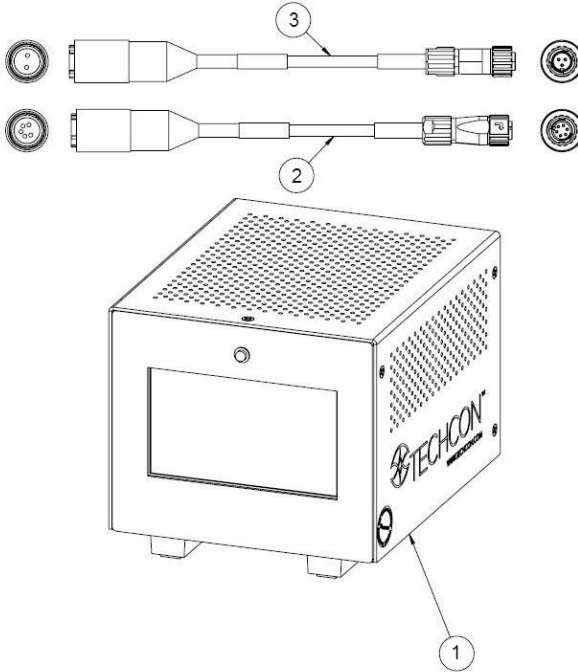

Figure 1B: TS980 Smart Controller

3. TS9800 PIEZO JET VALVE DESCRIPTION

The TS9800 Series Piezo Jet Valve is a piezoelectric driven, non-contact dispensing valve capable of handling fluid at different viscosities. Piezo Jet Valve offers a fast-jetting action producing hundreds of accurate deposits in less than one second.

Every component of the valve was designed to the highest tolerances and manufactured to the strictest degree of precision, ensuring world class accuracy and repeatability in drop-to-drop dispensing volume.

Piezo Jet Valve's compact size and modular design aids integration into robotic systems. The valve features fully adjustable parameter settings, allowing the operator to change the jetting properties for different fluid types and optimize the process for repeatable dispensing.

A variety of nozzle shapes and sizes, along with different tappet configurations, provides a wide spectrum of output jet deposits.

4. SET UP INSTRUCTIONS

4.1 Mounting & Connection

The TS9800 Series Piezo Jet Valve should be used on an automated XYZ table. It is very important that the valve is mounted on the Z-axis gantry, in a secure manner, that will not allow loosening during dispense operation.

Mount the valve to the XYZ table bracket through the two tap holes (M4). To prevent rust, it is recommended the bracket be made of stainless steel, galvanized steel, or non-ferrous metals. The screwing depth is about 6 mm.

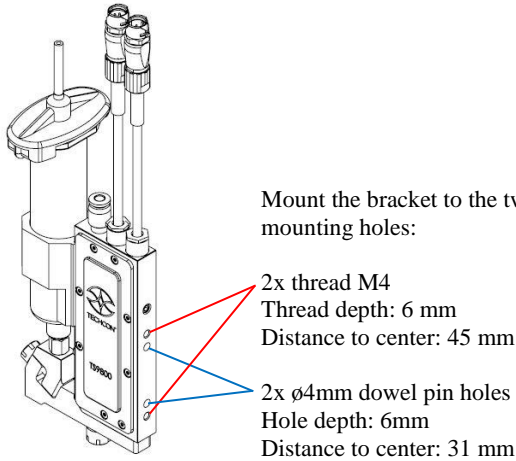

Figure 2: Mounting

The connection of the **TS9800 Piezo Jet Valve** to the **TS980 Smart Controller** is done via the 3-pin plug and the 6-pin plug on the top of the valve. The plugs are protected against mix-up by having different number of pins. After connecting, the plug must be locked in place by turning the locking nut on the cable's mating connector a quarter of a turn in a clockwise direction.

The 3-pin cable supplies the power for the piezo stack from 0 VDC to 100 VDC (bipolar operation). The 6-pin cable transfers the data of the integrated sensor inside the valve. Disconnection is done by first rotating the locking nut on the cable's mating connector a quarter of a turn in a counterclockwise direction, then gently pulling the connector axially backwards. **Caution:** Never disconnect the cables from the valve while the system is still dispensing, this will lead to damage to the valve and the control unit. If the system is not operating, you can disconnect the valve and the control unit.

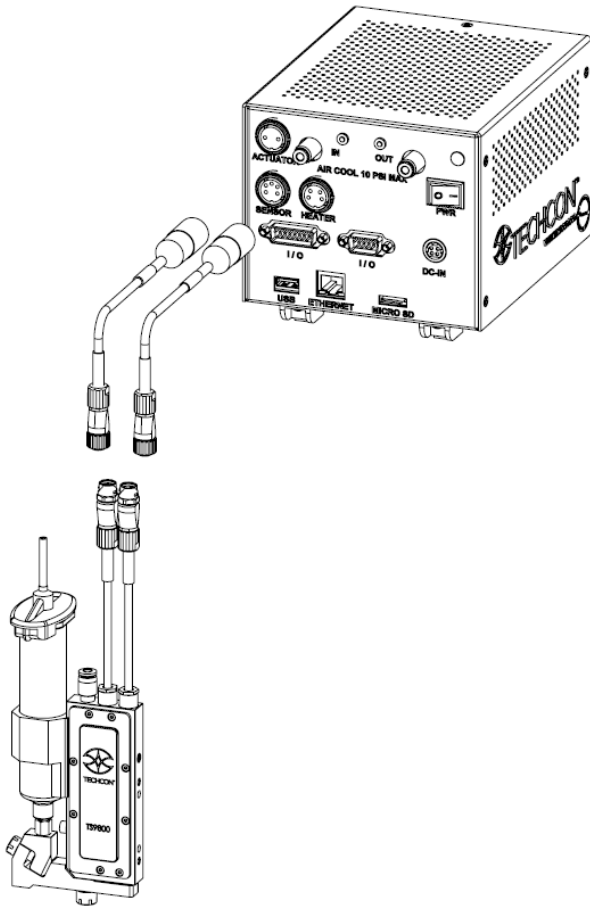

Figure 3: Connection

4.2 Setup

WARNING: Before starting the Jet Valve System, carefully read through this User Guide and pay attention to the **Warning** and **Caution** notices.

Note: Complete disassembly and maintenance instructions can be found in Section 7.

Step 1:

- Use the provided nozzle adjustment tool (1) to remove the nozzle adjustment nut/bushing assembly (2) and protective nylon washer (3).

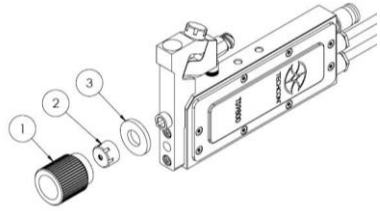

Step 2:

- Use the provided nozzle installation tool (4) to remove the nozzle bushing (5) from the nozzle adjustment nut (6).

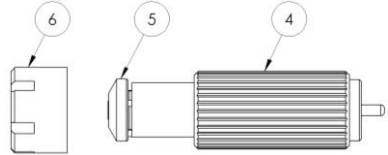

Step 3:

- Press the nozzle insert (7) into the nozzle bushing with the smaller end facing outward. **Caution:** To sit correctly, the nozzle insert must snap in lightly. Make sure it sits level within the socket.
- Place the bushing/nozzle insert assembly on the nozzle installation tool in the vertical position to prevent the nozzle insert from dropping out.



Step 4:

- Slowly screw the nozzle adjustment nut into the bushing/nozzle insert assembly. **Caution:** Continue to hold the assembly in the vertical position while hand-tightening the nozzle adjustment nut.

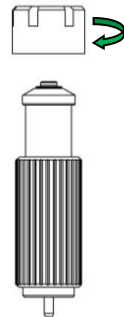

Step 5:

- Use the nozzle adjustment tool to securely tighten the assembly.

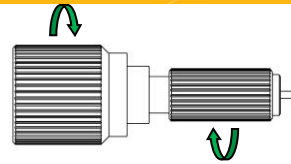
Step 6:

- Screw the nozzle unit (nozzle bushing, nozzle insert and adjustment nut) to the fluid manifold by hand (or use the nozzle adjustment tool) for about 3-4 turns only.

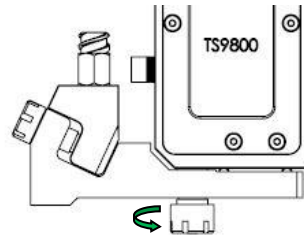
Step 7:

- To prevent fluid leakage during dispensing, make sure the fluid box adapter is tightened to the fluid manifold. Use the nozzle adjustment tool to tighten the locking screw.

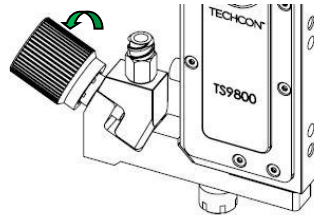

Step 8:

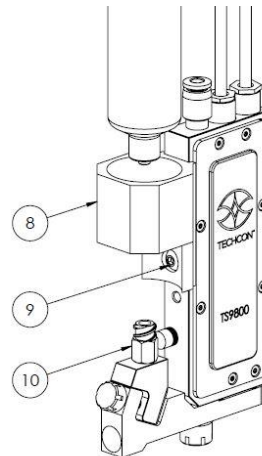
- Mount the syringe bracket (8) by placing it on the side of the valve, then use the 2.5 mm hex wrench to install the provided M4 screw (9) to the tapped hole and secure the bracket in place.
- Insert the material syringe through the bracket. Connect the syringe to the valve's luer-lock fitting (10). **Caution:** When removing the syringe, use 8 mm open-jaw hex wrench to hold the fitting tight to prevent it coming loose from the fluid box adapter.
- Mount the valve in the vertical position on a test stand or robot.

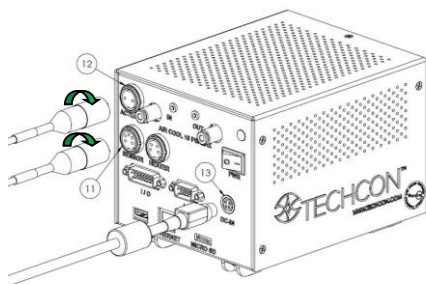

Step 9:

- Connect the valve cables to the controller. Sensor cable (6-to-5 pins) to the ‘SENSOR’ port (11); Actuator cable (3-to-2 pins) to the ‘ACTUATOR’ port (12). **Caution:** After connecting, tighten the locking sleeve to secure the connection.
- Connect the provided external power supply to the ‘DC-IN’ port (13).



Step 10:

- Connect the first $\varnothing 4$ mm OD air tubing from the air pressure source to the ‘IN’ port (14). **Caution:** This air source must be **regulated and filtered (dry)** separated from the air pressure source for the material syringe or reservoir.
- Connect the second $\varnothing 4$ mm OD air tubing from the ‘OUT’ port (15) to the air fitting on top of the Jet Valve (16).
- Turn up the air pressure for cooling to the maximum of 10 psi.

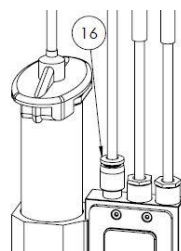
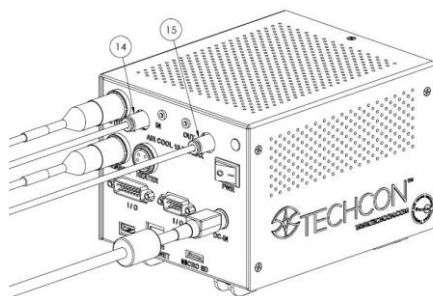

Step 11:

- The setup is now complete. Proceed to next section 4.3 to perform the nozzle calibration process.

4.3 Nozzle Calibration

The purpose of the nozzle calibration process is to make sure the nozzle insert is installed at the correct position with respect to the tappet to prevent leakage and to ensure proper dispensing.

Follow the instructions below before starting the actual dispense procedure.

WARNING:

- Make sure the nozzle unit is loose before turning the controller on.
- For proper calibration and operation, the jet valve must be securely mounted on a test stand or robot in the vertical position. Do not calibrate or operate the valve while it is placed insecurely on bench top.

1. Turn on the controller by pressing the On/Off switch.

2. Touch the 'Login' icon to enter the login screen. 

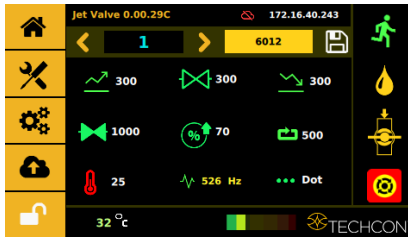

3. Enter the default password '0000' in the password window. Then touch the 'Accept' icon to save and exit.  **Attention:** For changing the password, refer to section 9.5.1.

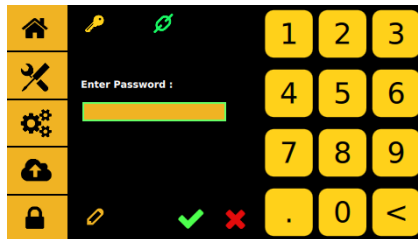

4. Make sure the valve is in the closed position. The 'Close' icon is shown on the home screen. 

- Start the calibration process by touching the ‘Calibration’ icon. 

Caution: For maximum calibration accuracy, do the following:

- Disconnect air or fluid pressure to the fluid inlet before starting the calibration process.
- If the fluid manifold with heater is being used, turn the heater on and allow the fluid manifold to warm up to the desired operating temperature, then turn off the heater before starting the calibration process (refer to Section 6 for more details on how to operate the heating system).

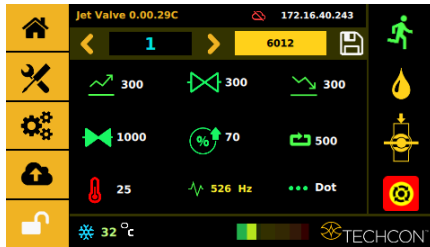

- Use your fingers to tighten the nozzle unit into the fluid manifold until it comes to a complete stop against the tappet.

Caution: Do not over-tighten the nozzle unit.

- Touch the “Start” icon to begin the calibration process.

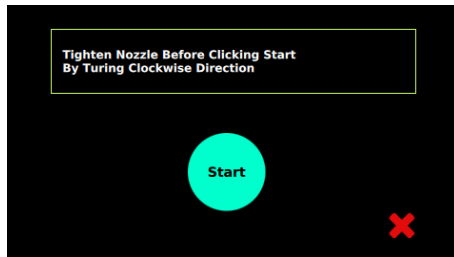

- The system will warm up and the calibration waveform will start right after warm-up shots.

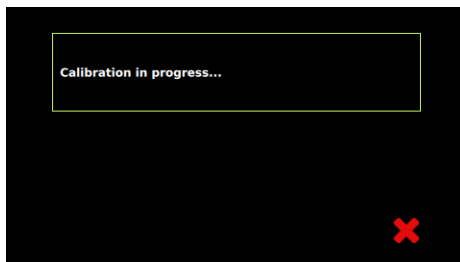

9. The system will take about 15 – 20 seconds for warming up and starting up the computation. During this time, the front panel calibration LED is off.
10. When the system completed the initial computation, the LED light will turn **Orange**.



11. Quickly loosen the nozzle unit by about quarter of a turn until the LED light turns **Red**.



12. Slowly tighten the nozzle unit to the calibrated position until the LED light turns **Green**.



Caution: Once the proper calibration condition is achieved, immediately go to step 12.

13. The calibration process is now completed. Touch the ‘Accept’ icon to save and exit. 

The valve is now ready for dispensing application.

Remarks:



- You can leave the calibration procedure by touching the ‘Accept’ icon.
- The calibration procedure should be done in a cleaned, dry system to avoid any influences of the material between nozzle insert and tappet and to get a consistent dispense result.
- If the fluid contains particles (fillers), the calibration procedure performed with fluid is not possible. It must be performed without fluid.

5. OPERATION

5.1 Start Dispensing

The valve is now ready to dispense. Dispensing fluid (via cartridge/syringe or reservoir) must be connected to the air pressure regulator.

Enter the desired dispensing parameters found in section 7.5.5 (Rising, Open Time, Falling, Delay, Needle Lift, and Number of Pulses), then touch the ‘Save’ icon. Information to the values can be found in the table for ‘essential parameters’ on the next page.

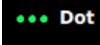
To start the dispensing, touch the ‘Run’  icon or use external start signal for both  Line or dot  Dot mode. When in line mode, ‘Run’ can only be activated or triggered by an external device.

Attention: Use the Purge feature to de-air (removal of air in the system) after going through the calibration procedure in section 4.3 (e. g. after the change of cartridge/syringe and/or after the removal of nozzle). To purge,

touch and hold the ‘Purge’ icon  and it will run the parameters in the current program until the purge icon is released.

5.2 Parameter Settings for the Dispensing Process

The TS9800 Piezo Jet Valve System works according to the control profile shown below:

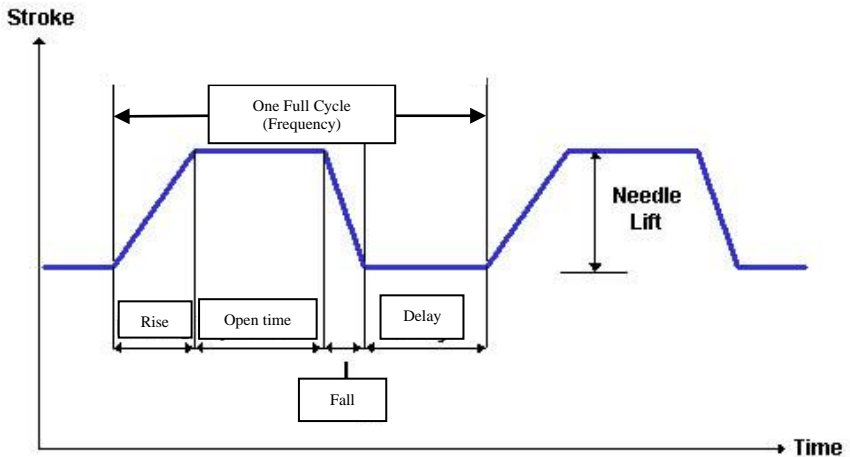

Figure 4: Control Curve

Essential Parameters:









FUNCTION	WHAT & WHY	SUGGESTION
RISE 	Time to lift the tappet from fully closed to opened positions	Minimum setting is 80 μ s
		Maximum setting is 1999 μ s
		Depending on fluid viscosity, start at about 300 μ s
		Rise time can also affect the accumulation or satellite
OPEN 	Time to allow material to fill the cavity and to jet out	For low viscosity material, open time can be set between 1 - 300 μ s
		For medium viscosity material, open time can be set between 200 - 1000 μ s
		For high viscosity material, open time can be set between 500 - 2500 μ s
		Smaller shot requires smaller open time
		Bigger shot requires larger open time
		Minimize the open time to keep the shot as clean as possible
FALL 	Time to jet out the material	Minimum setting is 80 μ s (smaller the value produces stronger the punch/jetting)
		Maximum setting is 1999 μ s (larger the value produces slower the punch/jetting)
		Higher viscosity material requires stronger punch setting
		Fall time can also affect the accumulation or satellite
		Slow down the fall time to reduce satellite
		Increase the fall time to reduce accumulation
DELAY 	Time between pulses	More important in Line Mode
		Important in Dot Mode if there are multiple pulses in one dot (number of pulses in a certain time)
		Delay time in single pulse/shot jetting is not important since the robot movement will take longer
		Shorter delay time produces closer dots as it tries to connect the dots to form the line
		Longer delay time produces dots which are further apart
		Higher lift produces stronger punch/jetting
LIFT 	Percentage the taper lifts from fully closed to opened positions	The valve is more stable with lift higher than 40%
		Higher lift produces more volume
		Lower lift produces less volume
		Higher lift and shorter fall time may be necessary for dispensing high viscosity material or stringy material. Activating heater may also help to reduce the lift percentage and fall time
		In Dot Mode, it can be set from 1 to 9999999 pulses
		In Line Mode, it defaults to pre-set value
PULSE 	Number of shots	One dot can be an accumulation of multiple pulses (e.g. one dot can be 1 pulse or 20 pulses)
		Multiple pulses can be set to increase dot size or use a larger diameter nozzle
		Help to stabilize the process
		Help to lower the material viscosity for better flow
HEATER 	Heater inside the fluid manifold	Help to reduce the stringiness of a material for better jetting
		Warning: Consult with the material manufacturer to prevent over-heating of material. Techcon will not be responsible for damages caused by hardened material inside the fluid manifold and/or nozzle

Table 1 – Essential Parameters

After entering the dispensing parameters, touch the ‘Save’ icon  to save all the parameters to the current program location. You can then start your dispensing process. **Note:** For more detail on how to enter the dispensing parameters, refer to section 9.5.3.

6. HEATING

6.1 Introduction

The TS9800 Piezo Jet Valve with heating system is available for heating high viscosity fluid.

The heating system also helps to maintain constant temperature. Required parts:

- TS9800 Piezo Jet Valve with heater
- Heater Cable
- Heat Guard Kit

6.2 Safety Instructions

- Use of the Piezo Jet Valve with heating system should only be done by trained staff.
- Carefully review the material safety data from the dispensing material.
- Wear adequate protective clothing before starting to dispense aggressive fluid.
- Be cautious that the media you want to dispense is applicable for use with a heating system.

Caution:

- When using the Piezo Jet Valve with heater, please consult with the material manufacture for proper operating temperature.
- Be aware of the exposed surface and fittings on the manifold. Do not touch the heater without protective wear. Failure to do so can result in serious burns and/or injuries.

6.3 Function

Resistance	All hydrous solvents (Media, organic acid, and base)
Maximum heater setting value	90°C
Supply Voltage	24 VDC
Power consumption	40 W

6.4 Mounting & Connection (w/ Heater)

Step 1:

- Slide the heat guard over the fluid manifold. The alignment is done by the nozzle adjustment nut and the fluid manifold with heating module.

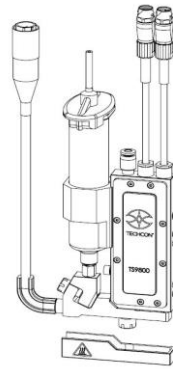

Step 2:

- Use the 4 mm hex wrench to install the provided M6 screw from the bottom to secure the heat guard in place. **Caution:** Do not over-tighten the screw because it can damage the heat guard.

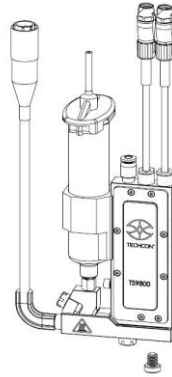



Step 3:

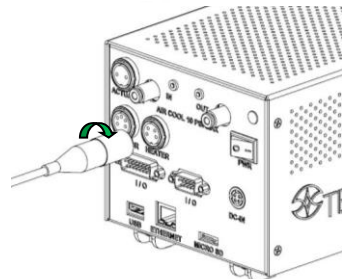
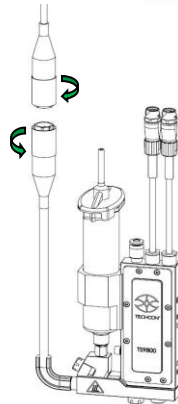

- Connect the heater cable (4-pins) from the valve's heating module to the 'HEATER' port of the controller. **Caution:** After connecting, tighten the locking sleeve to secure the connection.



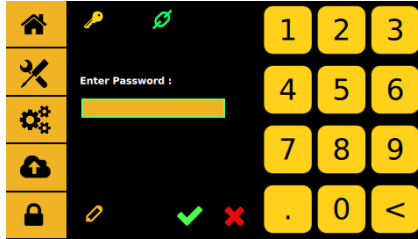

6.5 Setup

1. Touch the 'Login' icon to enter the login screen. 
2. Enter the default password '0000' in the password window. Then touch the 'Accept' icon to save and exit.  **Attention:** For changing the password, refer to section 9.5.1.



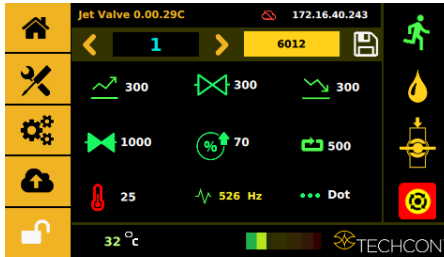

3. Touch the "Temperature" icon  to turn the heater ON and the icon will turn red. 



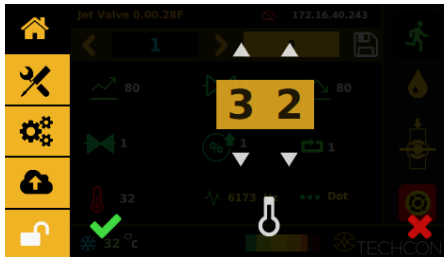

4. Touch the value field next to the temperature icon to enter the temperature setting screen. 



5. Touch the up and down arrows to set the desired temperature. Then touch the 'Accept' icon to save and exit.  **Note:** Maximum temperature setting is 90°C.
6. Watch the fluid manifold's temperature reading at the bottom of the screen.  Once this temperature reaches the temperature setting, then start the dispensing.

Caution: Do not touch nozzle or fluid manifold with your fingers once the heater is turned on. Use provided tools for making any adjustment if necessary.

7. Touch the 'Temperature' icon  again to turn the heater OFF and the icon will turn back to green. 

7. VALVE SETUP AND CLEANING

7.1 Valve Removal

1. Turn off or disconnect the fluid pressure to the material syringe or fluid supply line from the material reservoir.
2. Remove the material syringe from the luer-lock fitting. Make sure to use an 8 mm open-jaw hex wrench to hold the fitting tight while removing the syringe.
3. Switch off the control unit.
4. Disconnect all valve cables.
5. Remove the valve from the XYZ table.
6. The valve can now be taken apart for cleaning. Refer to section 7.3 for cleaning instructions.
7. After replacing the valve or control unit, repeat section 4.2 for setup and section 4.3 for nozzle calibration.

7.2 Installation of New Nozzle Insert

1. Turn off or disconnect pressure to the material syringe.
2. Unscrew the nozzle unit from the fluid manifold using the nozzle adjustment tool.

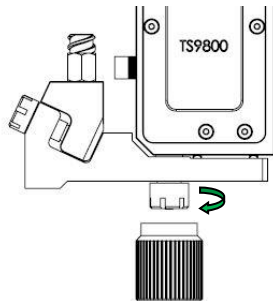

3. Unscrew the nozzle bushing/insert assembly from the nozzle adjustment nut using the nozzle installation tool.

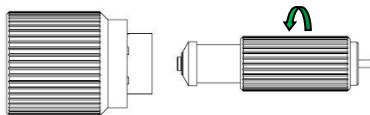

- Carefully remove the nozzle insert from the nozzle bushing.

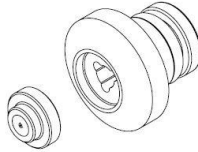

- Press the new nozzle insert into nozzle bushing with the smaller end facing outward. To sit correctly, the nozzle insert must snap in lightly. Make sure it sits level within the socket. Screw the assembly back into the nozzle adjustment nut using provided tools.

Caution: Keep the assembly in the vertical position while tightening to ensure the nozzle insert is properly seated. Use both tools to tighten the assembly.

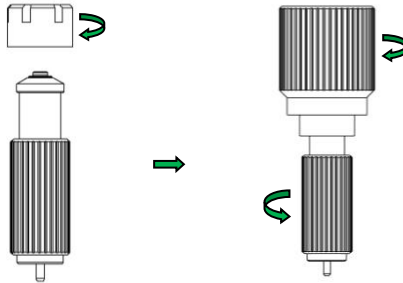

- Screw the nozzle unit back onto the fluid manifold and repeat section 4.3 for nozzle calibration.
- Re-connect or turn on the fluid supply and pressure. Run several purge cycles to remove air bubbles from the nozzle replacement. Wipe and clean the nozzle tip. The system is now ready for dispensing.

7.3 Cleaning

WARNING:

- Proper gloves and eye protection must be worn before disassembling the valve for cleaning.
- Never use wire brushes or machines that cause surface abrasion. Unsuitable cleaning fluids may damage the valve. Before using extremely aggressive cleaning liquids or solvents, make sure to check that all fluid contacting parts are compatible.

The Cleaning Tool Kit (9800-CLEANKIT-XX) consists of the following:

1. Pin Vise
2. Cleaning wires (-XX designates the wire diameter)
3. Cleaning brush

For pre-cleaning purposes, disconnect pressure, remove the dispensing fluid, then connect an empty but clean syringe to the valve. Use the pressurised air hook-up to the syringe to push out any fluid left in the valve.

The cleaning of the TS9800 Piezo Jet Valve can be carried out via:

➤ **Purge fluid path with appropriate cleaning solution**

To remove the remaining dispensed fluid, purge the system with an appropriate cleaning solution (refer to the material safety data sheet of the dispensed media and suitable cleaning solution). For this method, connect a syringe filled with an appropriate cleaning solution to the valve, then connect the syringe to the supply pressure. Touch and hold the ‘Purge’ icon



on the controller to purge the system. Run the purge until the system is clean. Ideally the only material left during the purging should be the cleaning solution. That is a good indicator the fluid path is clean.

➤ **Thorough Cleaning**

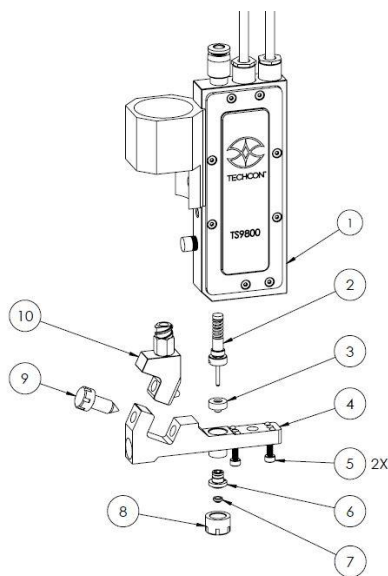

1. After purging the system with an appropriate cleaning solution, turn the system off and disconnect all connections to the valve.
2. Remove the nozzle unit by using the nozzle adjustment tool to rotate it counterclockwise.

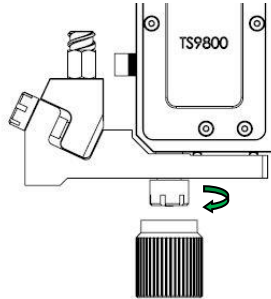

3. Remove the nozzle bushing (6) with the nozzle insert (7) from the nozzle adjustment nut (8) by using the nozzle installation tool to rotate it counterclockwise.

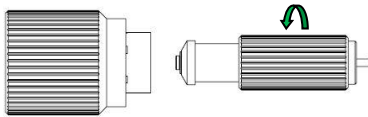

4. Remove the nozzle insert (7) from the nozzle bushing (6).

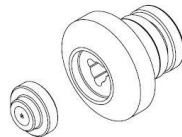

5. Remove the O-ring from the nozzle bushing. The pointed-tip tweezers can be used to pull the O-ring off. Be careful not to damage the nozzle bushing's surfaces. *(It's not recommended to reuse the O-ring after thorough cleaning)*



6. Use the provided 2 mm hex key to remove two holding screws (5) and carefully pull the fluid manifold assembly (4) from the upper valve body (1).

Attention: When re-assembling the fluid manifold assembly to upper valve body after cleaning, use the provided 2 mm hex wrench to tighten the two holding screws evenly (torque the screws to 5 - 6 lbf-in or 0.6 – 0.7 N-m).

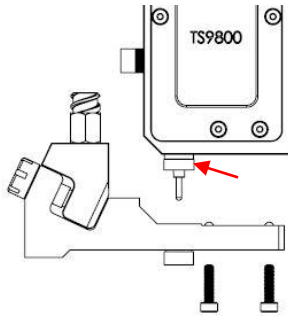

Attention: The tappet seal (3) usually remains on the tappet (red arrow), however if it's stuck in the fluid manifold, the tappet seal can be removed by inserting the provided tappet seal tool from the fluid manifold's outlet hole and slowly pushing upward on the seal.

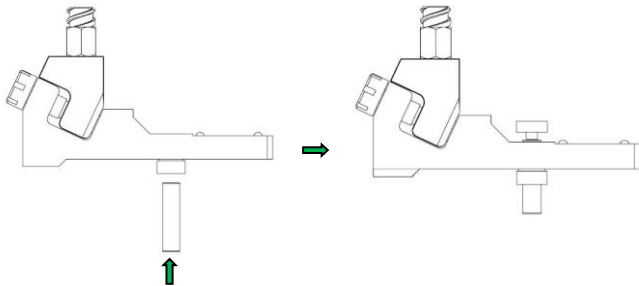

Follow the steps below to re-assemble the tappet seal after cleaning.

Caution: If the seal is installed backward, it will cause leakage.

- a. Top side of tappet seal.



- b. Bottom side of tappet seal.



- c. Slightly engage the tappet seal to the tappet in the orientation as shown.



- d. Push the tappet seal slowly onto the tappet until it presses firmly against the tappet bushing. While pushing the seal, do not allow the bottom section of the seal to over-stretch. **Caution:** Make sure the tappet seal sits tight or it may cause leakage.

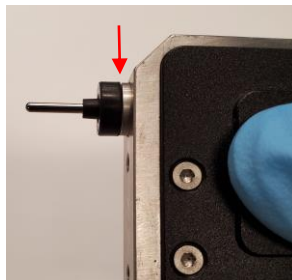
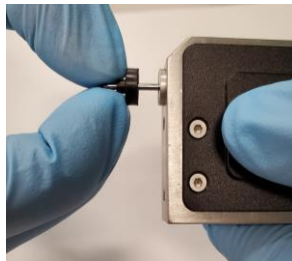

- Remove fluid box adapter assembly (10) from the fluid manifold (4) by using the nozzle adjustment tool to unscrew the locking screw (9).

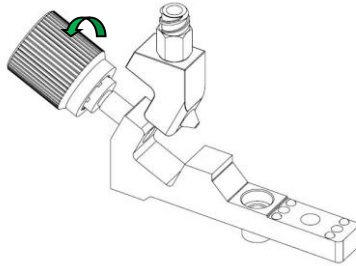

Attention: For the fluid manifold with heater, before using the nozzle adjustment tool to unscrew the locking screw, first remove the cable guide (11) so that it won't interfere with the tool.

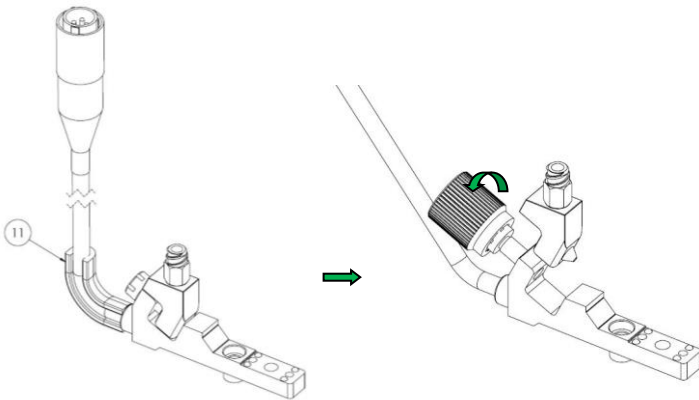

- Carefully remove the tappet seal from the tappet. Slightly squeeze both sides of the seal (blue arrows) and slowly pull the seal from the tappet.

Caution: Make sure that the seal does not become upended.

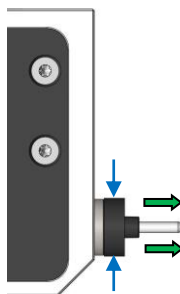

9. Use the tappet changing tool to unscrew the tappet assembly (2).

Attention: When re-assembling the tappet assembly to upper valve body after cleaning, make sure to apply Teflon grease to the areas of tappet and spring (blue arrows).

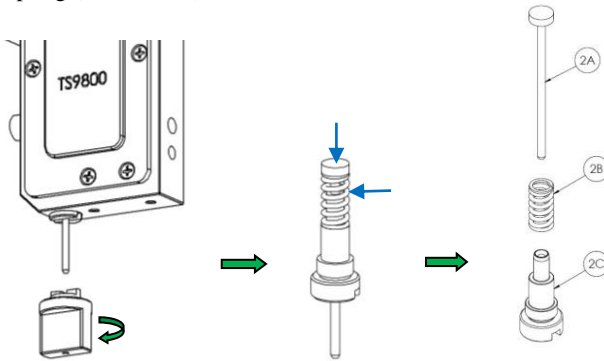

10. Unscrew the luer-lock fitting from the fluid box adapter using an 8 mm open-jaw hex wrench. Remove the O-ring from the luer-lock fitting. *(It's not recommended to reuse the O-ring)*

Attention: When re-assembling the luer-lock fitting to the fluid box adapter after cleaning, make sure to screw it tight to prevent fluid leakage (torque the fitting to 9 lbf-in or 1.0 N-m).

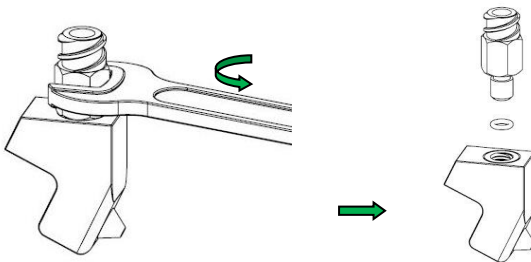

11. **Warning:** Refer to your facility regulations for proper solvent usage.

Attention:

- When using a cotton swab or cleaning brush for cleaning the part(s), always wet them with proper cleaning solution first.
- When moving the cleaning brush back and forth inside the part's bore for cleaning, always move it by rotating clockwise and counterclockwise.

Nozzle Insert:

- Thoroughly clean nozzle insert from above and below using a cotton swab. For the nozzle's orifice, clean and pierce through with cleaning wire using pin vise tool. **Note:** It's recommended to inspect nozzle insert under a microscope after cleaning to make sure that it's clean and free of material residue.

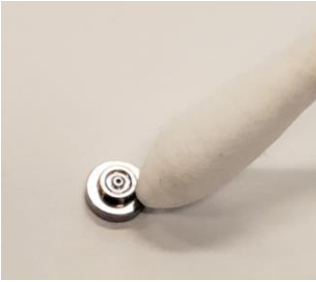
Nozzle Bushing:

- Use a cotton swab to clean the upper part of the nozzle bushing. Clean the outer part with cleaning brush.

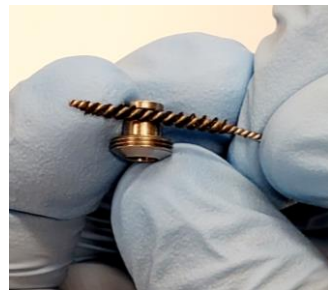

- Clean the bore of the nozzle bushing with cleaning brush. Move the brush back and forth several times to clean the bore of any material residue.



Fluid Manifold:

- Clean the conical surface and bore with a cotton swab.

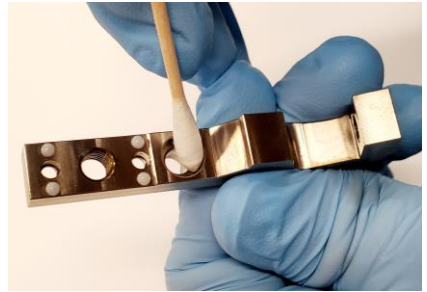
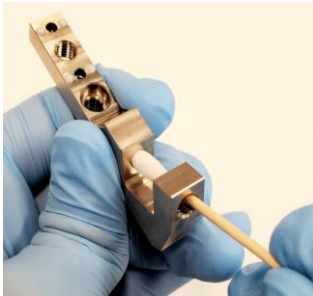

- Clean the fluid path with cleaning brush. Move the brush back and forth several times.



Fluid Box Adapter:

- Clean the opening with thread insert and the conical surface using a cotton swab.

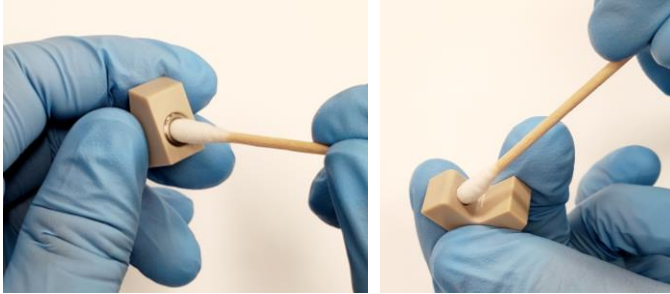

- Clean the bore with cleaning brush. Move the brush back and forth several times.

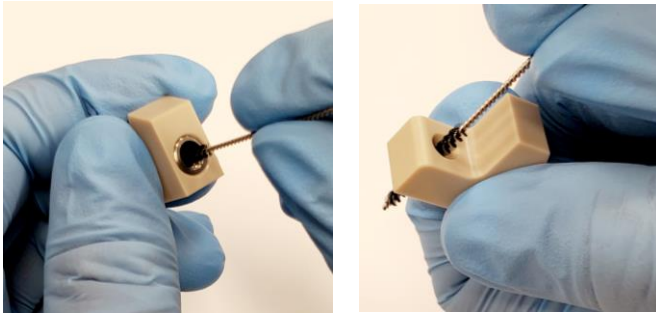
Luer-lock Fitting:

Clean the upper part with cotton swab. Clean the bore with cleaning brush. Move the brush back and forth several times.

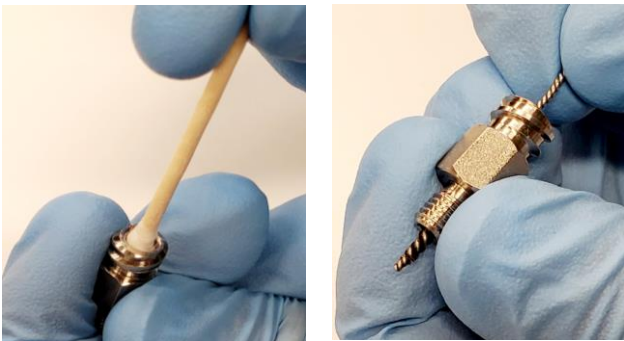

Adjustment Nut:

- Clean the internal and outer areas with cotton swab.

Tappet Bushing:

- Clean the bore from both ends with cleaning brush. Move the brush back and forth several times.

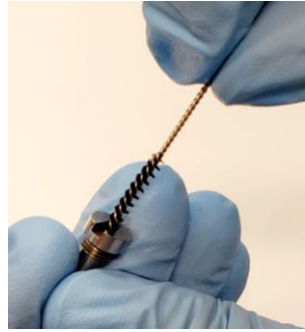
Tappet:

- Clean the tappet with lintless rag or wipe.

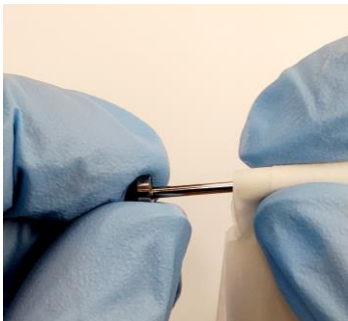

12. Clean components in an ultrasonic bath:
 - Place the nozzle bushing, tappet bushing, adjustment nut and tappet seal in a beaker. Fill the beaker with appropriate cleaning solvent until all parts are covered. Place the beaker in the ultrasonic bath for 15 – 20 minutes.
 - Place the fluid manifold, fluid box adapter, luer-lock fitting, and locking screw in a separate beaker. Fill the beaker with appropriate cleaning solvent until all parts are covered. Place the beaker in the ultrasonic bath for 15 – 20 minutes.
 - Place the nozzle insert and tappet in a separate beaker. Fill the beaker with appropriate cleaning solvent until all parts are covered. Place the beaker in the ultrasonic bath for 15 – 20 minutes.
13. After ultrasonic cleaning, remove components from cleaning solvent and dry them using compressed air.
14. The thorough cleaning process is completed. Re-assemble the valve by following steps 10 – 2.

Compatibility of sealing material with selected fluids

Substance	VITON	EPDM	NBR	Resistant materials
Acetone	non resistant	resistant	non resistant	
Ammonia	non resistant	non resistant	non resistant	PEEK, PTFE
Chloroform	resistant	non resistant	non resistant	
Cyclohexane	resistant	non resistant	resistant	
Cyclohexanol	resistant	non resistant	resistant	
Dimethyl formamide (DMF)	non resistant	resistant	non resistant	PEEK
Acetic acid	non resistant	non resistant	non resistant	PTFE
Ethanol	non resistant	resistant	resistant	
Heptane	resistant	non resistant	resistant	
Hexane	resistant	non resistant	resistant	
Isopropanol	resistant	resistant	partially resistant	
Methylene chloride	partially resistant	non resistant	non resistant	PEEK, PTFE
Nitromethane	non resistant	partially resistant	non resistant	PTFE
Pentane	resistant	non resistant	resistant	
Mercury	resistant	resistant	resistant	
Silicon oil	resistant	resistant	resistant	
Toluene	non resistant	non resistant	non resistant	PEEK, PTFE
Water	no information	no information	no information	PEEK, PTFE
Xylene	resistant	non resistant	non resistant	

Table 2 – Chemical compatibility of sealing materials

8. TS9800 PIEZO JET VALVE

8.1 Valve Modules

The TS9800 Series Piezo Jet Valve consists of three basic modules:

- Actuator System Module (1)
- Fluid Manifold Module (2)
- Nozzle Unit Module (3)

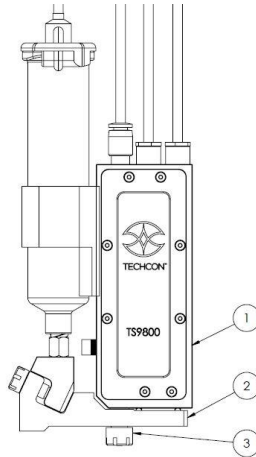

Figure 5: TS9800 Jet Valve

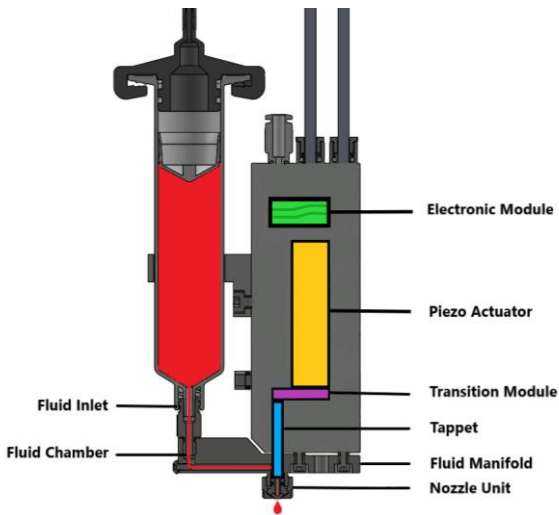

Figure 6: Jet Valve's internal operation

The actuator system is the heart of the Piezo Jet Valve. It contains the electronics for sensor and piezo actuator signals. It also contains the mechanics for the tappet drive. The housing is encapsulated to avoid contamination and intrusion of humidity.

Fluid Manifold can be easily removed from the actuator system by loosening two screws. This allows a stand-alone cleaning process.

Nozzle Unit can be easily changed and cleaned to minimized down time. The nozzle insert is a consumable item and can be easily replaced.

8.2 SPECIFICATIONS OF THE TS9800 SERIES PIEZO JET VALVE

Size	125 mm X 102 mm X 16 mm (4.9" X 4.0" X 0.63")
Weight	258 g
Minimum Shot Size	0.5 nl
Fluid pressure range	6.9 Bars (100 psi)
Fluid viscosity range	1 – 2 million cps
Operating Frequency	1-1500 Hz (Depending on Parameter Settings)
Continuous Load Dispensing Frequency	50-350 Hz
Response Time	1 μ s
Operating Temperature Range	10 – 50 °C (50 – 122 °F)
Wetted Parts	Stainless Steel, Tungsten Carbide, PEEK, EPDM, FFKM

8.3 SPECIAL FEATURES

8.3.1 Normally Open

In the non-operative mode, without supply voltage, the valve is opened. However, this is usually not a problem regarding fluid leakage. With high viscosity fluid, the valve will leak very slowly or not at all. In order to eliminate fluid leakage, the supply pressure to the material syringe must be disconnected before shutting down the control unit.

8.3.2 Quick-Change Concept

The “Quick-Change” (which consists of nozzle adjustment nut, nozzle bushing, O-ring seal and nozzle insert) allows a very fast exchange of the nozzle unit. The electronically controlled calibration process helps to adjust the nozzle unit quickly and precisely to the tappet.

8.3.3 Modularity

All TS9800 Jet Valve Systems are built strictly modular. Spare parts are simple and quick to replace so time and cost for repair can be significantly reduced.

8.3.4 Easy Handling

The valve can be controlled in all functions from the control unit and can be integrated into your existing setup.

8.4 Materials Applied

Only high-quality materials are used to manufacture the TS9800 Piezo Jet Valve System.

- All fluid contacting parts consist of high-alloyed, rust-proof, and acid-resistant stainless steels, as well as the high-performance polymer families of polyetheretherketone (PEEK) and FFKM.
- The nozzle inserts can be adapted to your dispense media and consist alternatively of two materials: Tungsten Carbide or Zirconia Ceramic.

9. TS980 JET VAVLE SMART CONTROLLER

9.1 Description

The TS980 Smart Controller consists of:

1. External universal power supply for all voltages
2. Electronically controlled heating regulator
3. Microprocessor-based for the TS9800 Piezo Jet Valve
4. Touch screen display with 272 X 480 RGB resolution
5. Various interfaces on the back side
6. On/Off switch for voltage supply

9.2 Technical Specifications

Property	Value
Dimensions	126 mm H x 137 mm W x 181 mm D (4.96" H x 5.40" W x 7.13" D)
Weight	2110 grams
Number of Parameter Storage Spaces	50 (49 STD program + a P prog)
Display	Color (White backlighting)
Maximum Heating Temperature	90 °C
Heating Circuits	1 (fluidic module heating)
Interfaces	DC power plug (24 VDC) 9 pin Sub-D EIA-232 (RS-232C) 15 pin Sub-D PLC (SPS) 3 x multi pin sockets 1 x USB port 1 x Ethernet port 1 x Micro SD card port 1 x On/Off switch
Operating Temperature Range	10 to 50 °C
Housing Colour	Black
Ventilation Concept	Convection Airing Internal Cooling Fan
Line Voltage	100 – 240 VAC
Line Frequency	50 / 60 Hz
Maximum Power Consumption	221 Watts

9.3 Features

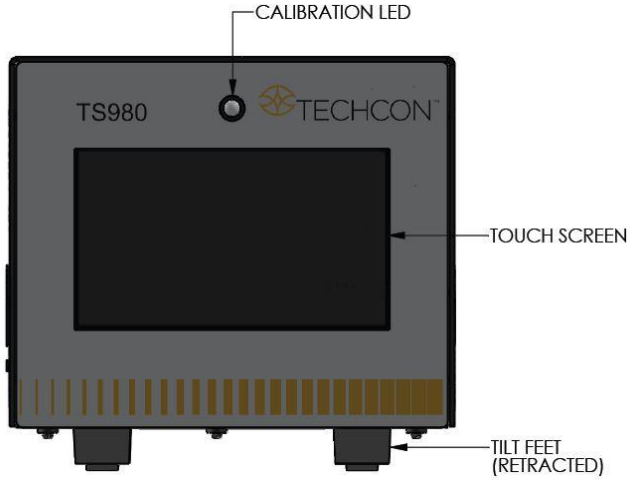

Figure 7: Front Face of the Jet Valve Controller

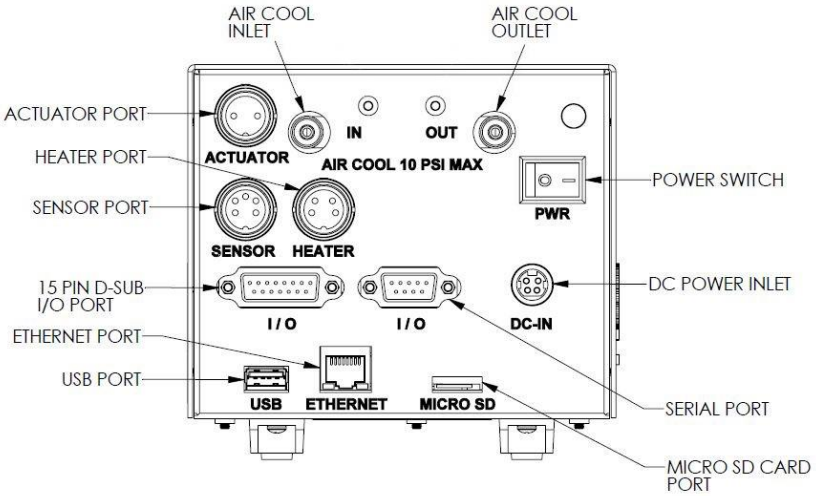











































Figure 8: Rear Face of the Jet Valve Smart Controller

9.4 Symbol Definitions

Symbol	Description	Symbol	Description
	Home Screen		Calibration
	Settings		IoT
	Login (Lock)		Logout (Unlock)
	Run (Start)		System Inhibit
	Purge (Press & Hold)		E-Stop
	Accept		Cancel
	Change Password		Counter Reset
	Run Method		Service Mode
	Wi-Fi Setting (Not Available)		Remote Server
	USB Application Update		Dot Mode
	Line Mode		Continuous Cycle (Repeat Mode)
	Rise Time		Fall Time
	Open Time		Delay Time
	Percentage Lift		Pulse
	Valve Open		Valve Close (Closed when system is ON)
	Heater Off		Heater On
	Heater is Idling/Off		Heater is On and Heating Up
	Save		Line Mode (External Trigger)
	Password Lock		Password Unlock
	Master Password Reset		IP Address for Ethernet Connection



9.5 Operation

9.5.1 Login

1. Touch the 'Login' icon to enter the login screen. 
2. Enter default password '0000' in the password window.

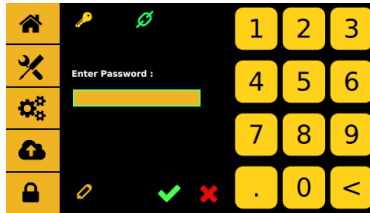
Attention: To change the password, skip step 2 and proceed to step 4.



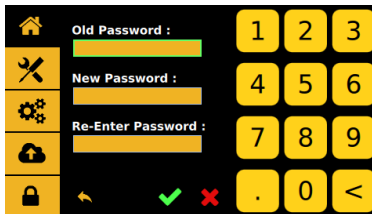

3. Touch the 'Accept' icon to save and exit. 
4. To change the password, touch the 'Change Password' icon. 





5. Enter the old password, then enter the new password.
6. Touch the 'Accept' icon to save and exit. 

9.5.2 Disable Password Protection (Keep Controller in Unlock Mode)

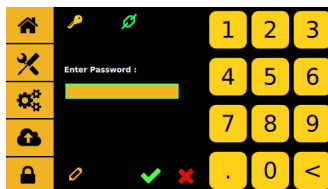
1. Touch the 'Login' icon to enter the login screen. 
2. Enter default password '0000' in the password window and touch the lock icon.  The lock icon will switch to an unlock icon  indicating that the login icon will stay unlocked until it gets switched back.



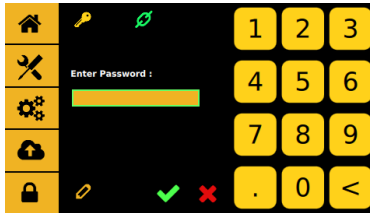

9.5.3 Enable Password Protection (Keep Controller in Lock Mode)

1. Touch the 'Login' icon to enter the login screen. 
2. Enter default password '0000' in the password window and touch the unlock icon.  The unlock icon will switch to a lock icon  indicating that the login icon will lockup with every login and logout.



3. Touch the 'Accept' icon to save and exit. 

9.5.4 Reseting Master Password (Please call TECHON for Master Password)

1. Touch the 'Login' icon to enter the login screen. 
2. Enter password 'xxxx' in the password window and touch the master reset icon. 

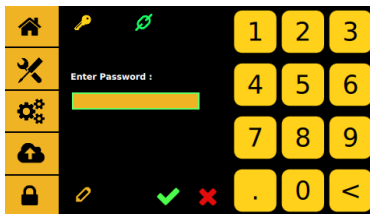

3. If the master password is correct, the next menu will pop up.

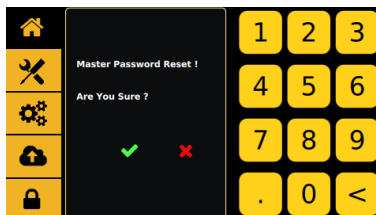

4. Touch the 'Accept' icon  to accept and exit.
5. Once the master password is confirmed, the password will reset to **0000**.



9.5.5 Setup Dispensing Parameters

All essential dispensing parameters can be accessed from the home screen.

1. Touch the 'Rise Time' icon to enter the setup screen. 
2. Touch the up and down arrows to set the desired rise time in μs .



Attention: The minimum rise time is 80 μs and the maximum rise time is 1999 μs .

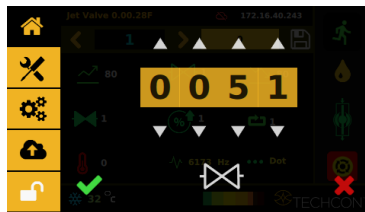

3. Touch the 'Accept' icon  to exit.
4. Touch the 'Open Time' icon  to enter the setup screen.
5. Touch the up and down arrows to set the desired open time in μs .

Attention: The minimum and maximum open time is 1 to 9999 μs .



6. Touch the 'Accept' icon  to exit.
7. Touch the 'Fall Time' icon  to enter the setup screen.

- Touch the up and down arrows to set the desired fall time in μs .

Attention: The minimum fall time is 80 μs and the maximum fall time is 1999 μs .



- Touch the 'Accept' icon to exit. 

- Touch the 'Delay Time' icon to enter the setup screen. 

- Touch the up and down arrows to set the desired delay time in μs .

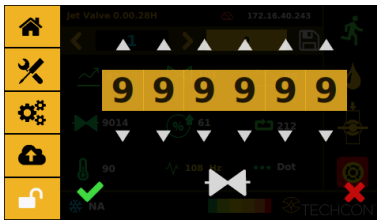

- Touch the 'Accept' icon to exit. 

- Touch the 'Percentage Lift' icon to enter the setup screen. 

- Touch the up and down arrows to enter the desired percentage lift for the tappet to open/lift.

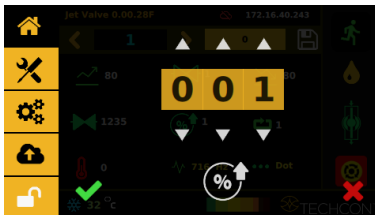



- Touch the 'Accept' icon to exit. 

- Touch the 'Pulse' icon to enter the setup screen.

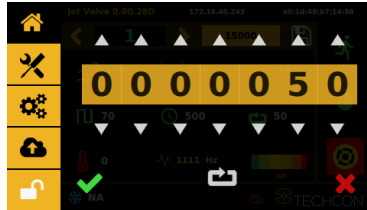
- Touch the up and down arrows to set the desired number of strokes per dispensing cycle.



- Touch the 'Accept' icon to save and exit 
- Enter all desired dispensing parameters, then touch the 'Save' icon. 

Note: The system will automatically calculate and display the operating frequency  based on the entered dispensing parameters.

9.5.6 Calling Up Dispensing Parameters

The controller has 50 memory cells store all dispensing parameters.

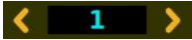
- Touch the forward or backward arrow to select the desired memory cell or touch the value to type in a specific location. 

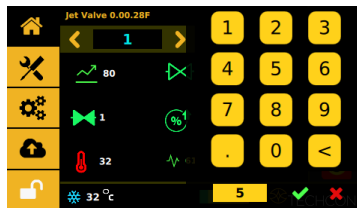

- Touch the 'Accept' icon to exit. 

9.5.7 Reset Cycle Counter



The cycle counter records the number of dispense cycle being activated. Up to 999,999,999 cycles can be recorded for each of the programs saved in memory. To reset the counter for the current program, follow the steps below:

1. Touch the 'Settings' icon to enter the setup screen. 



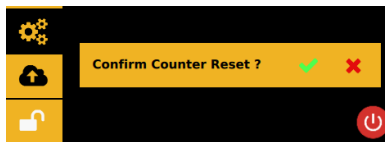

2. Touch the 'Counter Reset' icon to reset the counter. 



3. Touch the 'Accept' icon to confirm  or touch the 'Cancel' icon  to exit without resetting counter.

9.5.8 To Run in Dot or Line Mode

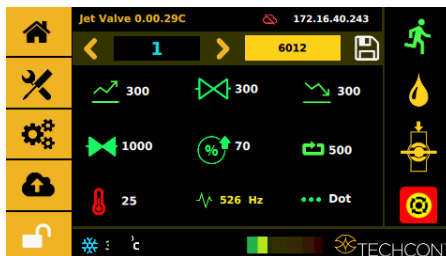

1. Touch to toggle between the line  or dot  icons to switch mode. **Note:** switching from Line to Dot mode may required a re-entry of a specific number of pulses desired to run the parameter or setup.





2. Touch the 'Run' icon to start the dispensing cycle. 
3. If Line Mode is selected, an external triggering device is required to trigger a start.

Caution: For Line mode, the controller must be activated by a secondary source such as PLC or XYZ Table connected through the 15-Pin I/O port.

9.5.9 Service Mode

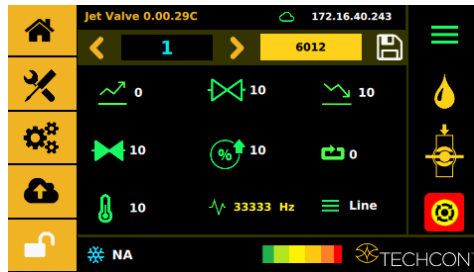
1. Touching the valve 'Close' icon  will toggle to the valve 'Open' icon  which opens the valve for de-airing or purging (stay open).



2. Touch the valve 'Open' icon  to toggle to the valve 'Close' icon  which closes the valve. This is a normal operation mode.

Attention: The valve does not jet the material in this mode, the material flows under regulated pressure only.

9.5.10 IoT (Remote Communication)

Note: Ethernet must be connected and it should already have an IP address



1. Touching the Setting icon  will toggle to the menu below.

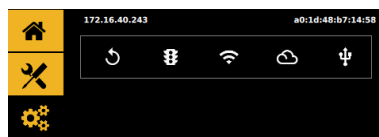

- Touch the cloud icon  to prompt up the Remote sever.

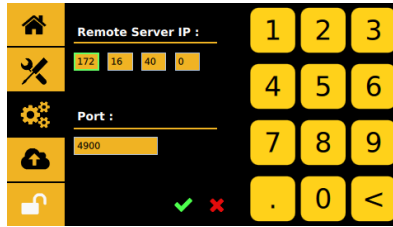

- Enter in the Remote sever IP and use the 4900 default for the Port.

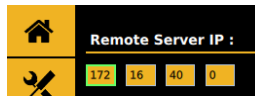

- If the connection is successful, a Green Cloud should appear.

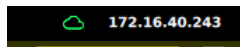

- Use any TCP/IP tool setup as a server to remotely retrived.
@<Program Number>
- Use any TCP/IP tool setup as a server to remotely update.
#<Program Number>#<Profile Data>

Profile Data example:

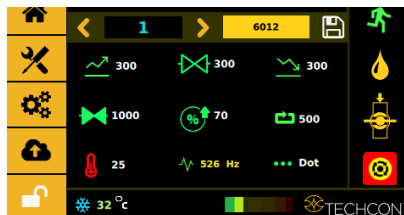

```
#1#{"cycleCount":"6012","delay":"1000","dutyCycle":"7","dwell":
":300","fallTime":"300","mode":0,"nozTemp":"25","nozTempSta
te":false,"programValue":1,"riseTime":"300","totalCycles":"500"
}
```

7. Change any of the highlighted values to the desired setting and update the program. **Note: Dot mode is 0, and line mode is 1. Heater Off is False, On is True, and make sure the red value matches.**
8. If update is a success, this screen will appear

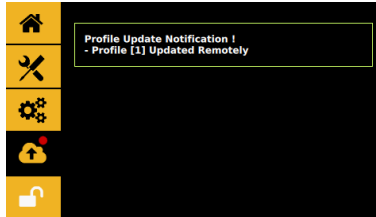

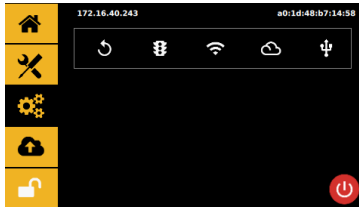

9.5.11 Software Update

1. Download the latest software version from the Techcon website and copy it to a blank USB thumb drive. **Caution:** The software file must be placed in the root directory.
2. Insert the USB drive into the USB port located in the back of the unit.
3. Touch the 'Settings' icon to enter the setup screen. 

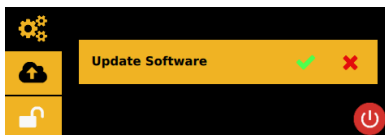

4. Touch the 'Application Update' icon. 



5. Touch the 'Accept' icon to update the software. 
6. Wait until the update is completed. Remove USB drive.

10. SPARE PARTS AND SCHEMATICS

10.1 Tappets & Nozzle Inserts

PART NO.	DESCRIPTION
TAPPETS	
9800-TT-TC-07	TAPPET, TUNGSTEN CARBIDE, 0.7 mm TIP
9800-TT-TC-15	TAPPET, TUNGSTEN CARBIDE, 1.5 mm TIP
NOZZLE INSERTS	
9800-NI-TC-50	NOZZLE INSERT, TUNGSTEN CARBIDE, 50µm
9800-NI-TC-70	NOZZLE INSERT, TUNGSTEN CARBIDE, 70µm
9800-NI-TC-100	NOZZLE INSERT, TUNGSTEN CARBIDE, 100µm
9800-NI-TC-120	NOZZLE INSERT, TUNGSTEN CARBIDE, 120µm
9800-NI-TC-150	NOZZLE INSERT, TUNGSTEN CARBIDE, 150µm
9800-NI-TC-200	NOZZLE INSERT, TUNGSTEN CARBIDE, 200µm
9800-NI-TC-300	NOZZLE INSERT, TUNGSTEN CARBIDE, 300µm
9800-NI-TC-400	NOZZLE INSERT, TUNGSTEN CARBIDE, 400µm

10.2 Tools

PART NO.	DESCRIPTION	
9800- TOOLKIT	7511-0540	NOZZLE INSTALLATION TOOL
	7511-0550	NOZZLE ADJUSTMENT TOOL
	7511-0560	TAPPET CHANGING TOOL
	7511-0690	TAPPET SEAL TOOL
	5400-0026	HEX WRENCH, L-KEY, 2mm
9800-CLEANKIT-05	CLEANING KIT, 50 µm WIRE	
9800-CLEANKIT-07	CLEANING KIT, 70 µm WIRE	
9800-CLEANKIT-10	CLEANING KIT, 100 µm WIRE	
9800-CLEANKIT-12	CLEANING KIT, 120 µm WIRE	
9800-CLEANKIT-15	CLEANING KIT, 150 µm WIRE	
9800-CLEANKIT-20	CLEANING KIT, 200 µm WIRE	
9800-CLEANKIT-30	CLEANING KIT, 300 µm WIRE	
9800-CLEANKIT-40	CLEANING KIT, 400 µm WIRE	

10.3 Piezo Jet Valve Parts List

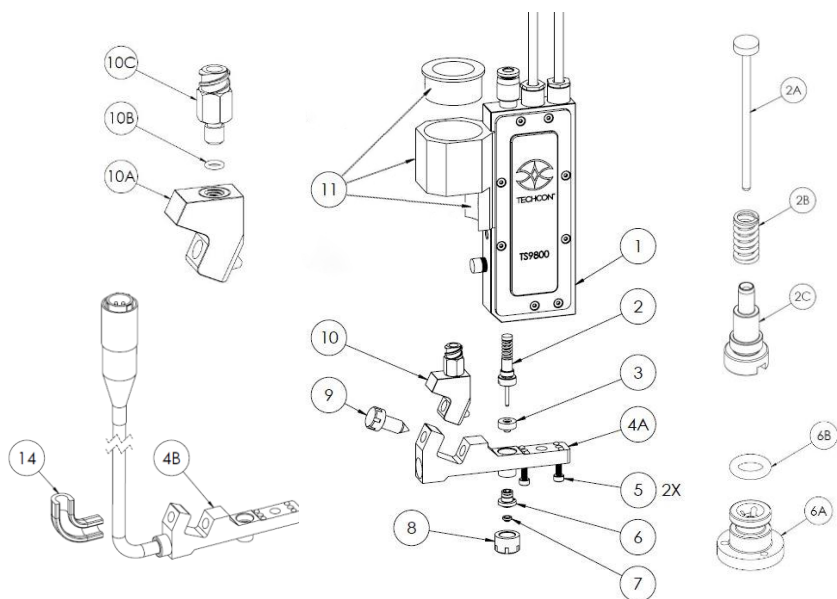

Figure 9: Jet Valve Assembly

ITEM	PART NO.	DESCRIPTION	QPA
1	7511-9100	ASSEMBLY, VALVE BODY	1
2	7511-9140-07	ASSEMBLY, TAPPET, 0.7 mm TIP	1
	7511-9140-15	ASSEMBLY, TAPPET, 1.5 mm TIP	1
2A	9800-TT-TC-07	TAPPET, TUNGSTEN CARBIDE, 0.7 mm TIP	1
	9800-TT-TC-15	TAPPET, TUNGSTEN CARBIDE, 1.5 mm TIP	1
2B	3300-0632	TAPPET SPRING	1
2C	7511-0490	TAPPET BUSHING	1
3	9800-SEALKIT	TAPPET SEAL, FFKM (QTY: 5)	1
4A	7511-9130	ASSEMBLY, FLUID MANIFOLD, LESS HEATER	1
4B	7511-9120	ASSEMBLY, FLUID MANIFOLD, HEATER	1
5	2800-0981	MOUNTING SCREW, FLUID MANIFOLD	2
6	7511-9160	ASSEMBLY, NOZZLE BUSHING, STAINLESS STEEL	1
6A	7511-0480	NOZZLE BUSHING, STAINLESS STEEL	1
6B	9800-ORINGKIT	O-RING, EPDM (QTY: 10)	1
7	9800-NI-TC-XX	NOZZLE INSERT, TUNGSTEN CARBIDE (SEE NOZZLE SALE P/N ON PAGE 57)	1
8	7511-0470	ADJUSTMENT NUT	1
9	7511-0180	LOCKING SCREW	1
10	7511-9180	ASSEMBLY, FLUID BOX ADAPTER W/LUER FITTING	1
10A	7511-0170	FLUID BOX ADAPTER	1
10B	9800-ORINGKIT	O-RING, EPDM	1
10C	TSD931-63	LUER FITTING	1
11	9800- SYRBRACKET	SYRINGE BRACKET	1
12	7511-0760	CABLE GUIDE	1

Piezo Jet Valve Parts List (continued)

Figure 10: Optional Cables

ITEM	PART NO.	DESCRIPTION	QPA
13	9800-ACABLE-5M	ACTUATOR CABLE, 5 m	1
14	9800-SCABLE-5M	SENSOR CABLE, 5 m	1
15	9800-HCABLE-5M	HEATER CABLE, 5 m	1
16	9800-ACABLE-AD	ADAPTER FOR ACTUATOR CABLE	1
17	9800-SCABLE-AD	ADAPTER FOR SENSOR CABLE	1

10.4 DB-15 I/O Port Functions

Note: Digital output requires a pull up resistor to the positive supply of the receiving device.

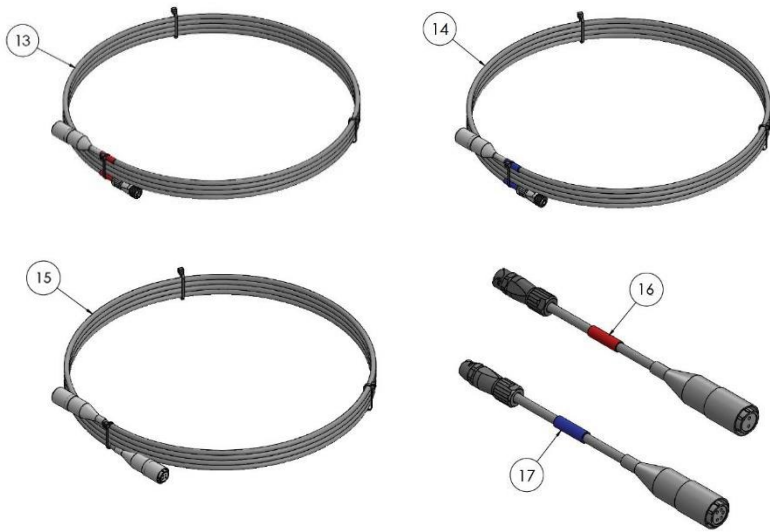
DB-15 CONNECTOR					
PIN	FUNCTION	I/O	TYPE	DESCRIPTION	LEVELS
1	VOLTAGE OUT	O	PW	Reference – 24VDC	-
2	NC	-	-	-	-
3	HEATER TEMP STATUS	O	DI	Signal when fluid manifold heater has reached targeted temperature	0V Target reached 0-24V Pulse Target not reached
4	ERROR OUT	O	DI	Signal if any error or warning is present	0V Error/Warning Active 24V No Error/Warning has occurred
5	NC	-	-	-	-
6	TRIGGER OUT	O	DI	Trigger to outside device. It's square wave that is high when tappet lifts, low when tappet closes	+V When tappet lifts 0V When tappet closes
7	TRIGGER IN	I	DI	Trigger dispensing process from outside device such as external robot or PLC	24V Valve Idling 0V Valve Dispensing
8	GROUND COMMON	O	PW	Reference – GND	-
9	NC	-	-	-	-
10	NC	-	-	-	-
11	VALVE OVERTEMP	O	DI	Signal when the Piezo temperature has exceeded +85°C operating limit	0V Temperature exceeded 24V Temperature is within range
12	NC	-	-	-	-
13	NC	-	-	-	-
14	NC	-	-	-	-
15	GROUND COMMON	O	PW	Reference – GND	-

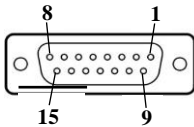

Note: DI: Digital Input
 DO: Digital Output
 PW: Power

10.5 Serial Port Functions

Note: Serial port is currently not activated.

DB-9 CONNECTOR					
PIN	FUNCTION	I/O	TYPE	DESCRIPTION	LEVELS
1	NC				
2	NC				
3	NC				
4	NC				
5	NC				
6	NC				
7	NC				
8	NC				
9	NC				

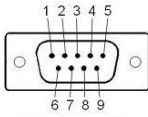

11. TROUBLESHOOTING

11.1 General Problems

PROBLEM	WHAT & WHERE	SUGGESTION
ERROR	Readout on controller	Piezo is over-heating. Slow down the dispense parameters. Adjust for longer dwell time (wait for the temperature to drop before starting again)
		Intermittent. RTD connection may have a problem
		Check connection of sensor cable
LEAKAGE	Between valve body and fluid manifold	Loosen two holding screws and re-align the fluid manifold. Torque the screws to 5 lb-in (0.56 N-m)
		Replace tappet seal
		Replace tappet
	Nozzle	Re-calibrate
		Replace tappet and/or nozzle
	Air from valve	Air cool is turned on (normal) ERROR message is displayed (see ERROR section)
REBOOTING	Controller keeps rebooting	Disconnect actuator cable, if controller reboots and stays on then the Piezo is shorted. Return valve to Techcon for evaluation
NOT DISPENSING	Valve is not running	Check connection of actuator cable
		Manual dispensing must be in Dot Mode
		Line Mode requires external trigger. Check external triggering device
	Valve is running but no fluid comes out	Nozzle might be clogged. Remove nozzle for cleaning
		Syringe pressure must be connected
DISPENSING W/OUT ACTIVATION	Drops or stream of material is coming out from nozzle	Re-calibrate
		System must be turned on since the valve is normally opened without power
		Make sure that the "Valve Close" icon in the main menu is in the Close Mode
		Tighten up nozzle/nut assembly and re-calibrate
FREEZE	Touch screen is frozen	Refer to LEAKAGE section
		Reset system using the On/Off switch located in the back of the controller

11.2 Key Variables

Variables	Effects
Fluid Pressure <ul style="list-style-type: none"> Droplet size can be adjusted by changing fluid pressure 	<ul style="list-style-type: none"> Droplet size can be adjusted by changing fluid pressure Too much fluid pressure can cause accumulation Too little fluid pressure can cause inconsistent dot size or “starvation”
Nozzle Size <ul style="list-style-type: none"> Determine the droplet size 	<ul style="list-style-type: none"> Bigger nozzle size will produce bigger dot size or line width Smaller nozzle size will produce smaller dot size or line width
Needle Lift (stroke length) <ul style="list-style-type: none"> Range = 50 – 95% 	<ul style="list-style-type: none"> Too high needle lift may cause satellite Too short needle lift may cause accumulation
Open Time <ul style="list-style-type: none"> Droplet size can be adjusted by changing open time 	<ul style="list-style-type: none"> Increasing open time will increase dot size Decreasing open time will decrease dot size
Jet Distance <ul style="list-style-type: none"> Distance between nozzle and substrate Distance range = 3 – 10 mm 	<ul style="list-style-type: none"> Too high jet distance can cause satellite Too short jet distance can cause accumulation

11.3 Nozzle Selection

Nozzle Size (µm)	Dot weight (µg) SG = 1	Dot Diameter (µm)
50	0.5-10	180-300
70	5-25	250-400
100	15-50	390-580
120	25-80	430-550
150	60-100	580-650
200	80-200	640-800
300	100-300	700-1500
400	200-500	1400-2000

11.4 Sample Parameters

Note: Parameters shown are for references only

- Low Viscosity**

Jet Valve	Techcon TS9800 (Non-Heater)
Nozzle Size	70 μ m Tungsten Carbide
Tappet Size	1.5 mm Tungsten Carbide
Robot	Techcon TS2301
Material	LOCTITE 3105 - 200-400 cps (in 30 cc syringe)
Dispensing Parameters - DOTS	
Rise	200 μ s
Fall	250 μ s
Open Time	100 μ s
Delay Time	5000 μ s
Lift	52%
Pulse	1
Frequency	180 Hz
Dispense Height	3 mm
Fluid Pressure	10 psi
Valve Cooling	NA
Shot Diameter	0.59 mm

Jet Valve	Techcon TS9800 (Non-Heater)
Nozzle Size	70 μ m Tungsten Carbide
Tappet Size	1.5 mm Tungsten Carbide
Robot	Techcon TS2301
Material	LOCTITE 3105 - 200-400 cps (in 30 cc syringe)
Dispensing Parameters - LINES	
Rise	200 μ s
Fall	250 μ s
Open Time	200 μ s
Delay Time	3500 μ s
Lift	46%
Pulse	-
Frequency	241 Hz
Dispense Height	2.2 mm
Fluid Pressure	10 psi
Valve Cooling	10 psi
Line Width	0.82 mm

- **Medium Viscosity**

Jet Valve	Techcon TS9800 (Non-Heater)
Nozzle Size	120 μ m Tungsten Carbide
Tappet Size	1.5 mm Tungsten Carbide
Robot	Techcon TS2301
Material	Loctite 3103 - 14.5 KCps (in 30 cc syringe)
Dispensing Parameters - DOTS	
Rise	300 μ s
Fall	120 μ s
Open Time	1000 μ s
Delay Time	3000 μ s
Lift	80%
Pulse	10
Frequency	226 Hz
Dispense Height	4.0 mm
Fluid Pressure	56 psi
Valve Cooling	10 psi
Shot Diameter	1.51 mm

Jet Valve	Techcon TS9800 (Non-Heater)
Nozzle Size	120 μ m Tungsten Carbide
Tappet Size	1.5 mm Tungsten Carbide
Robot	Techcon TS2301
Material	Loctite 3103 - 14.5 KCps (in 30 cc syringe)
Dispensing Parameters - LINES	
Rise	300 μ s
Fall	120 μ s
Open Time	1000 μ s
Delay Time	3000 μ s
Lift	80%
Pulse	-
Frequency	226 Hz
Dispense Height	4.0 mm
Fluid Pressure	56 psi
Valve Cooling	10 psi
Shot Diameter	1.1 mm

- **High Viscosity**

Jet Valve	Techcon TS9800 (Non-Heater)
Nozzle Size	200 μ m Tungsten Carbide
Tappet Size	1.5 mm Tungsten Carbide
Robot	Techcon TS2301
Material	Loctite 3609 - 220 KCps (in 30 cc syringe)
Dispensing Parameters - DOTS	
Rise	320 μ s
Fall	120 μ s
Open Time	1250 μ s
Delay Time	5000 μ s
Lift	82%
Pulse	1
Frequency	149 Hz
Dispense Height	3.5 mm
Fluid Pressure	52 psi
Valve Cooling	NA
Shot Diameter	0.41 mm

Jet Valve	Techcon TS9800 (Non-Heater)
Nozzle Size	200 μ m Tungsten Carbide
Tappet Size	1.5 mm Tungsten Carbide
Robot	Techcon TS2301
Material	Loctite 3621 - 130 KCps (in 30 cc syringe)
Dispensing Parameters - DOTS	
Rise	220 μ s
Fall	115 μ s
Open Time	1050 μ s
Delay Time	12000 μ s
Lift	85%
Pulse	1
Frequency	75 Hz
Dispense Height	2.0 mm
Fluid Pressure	27 psi
Valve Cooling	NA
Shot Diameter	0.58 mm

12. WARRANTY AND RETURN

12.1 Warranty

Warranty refers to the reliability of the TS9800 Piezo Jet Valve System under conditions of ordinary use.

Warranty of the TS9800 Piezo Jet Valve covers all defects that could arise within a maximum period of 6 months or a billion pulses on the piezo actuator (whichever comes first) after the date of delivery.

Warranty of the TS980 Jet Valve Smart Controller covers all defects that could arise within 12 months after the date of delivery.

Should the TS9800 or the TS980 malfunction within the period of warranty, Techcon will carry out the repair free of charge. The failure must be notified in written form to Techcon.

In no event shall any liability or obligation of the manufacturer arising from this warranty exceed the purchase price of the equipment. This warranty is only valid if the defective product is returned as a complete assembly without physical damage.

The manufacturer's liability, as stated herein, cannot be altered or enlarged except by a written statement signed by an officer of the company. In no event shall the manufacturer be liable for consequential or incidental damages.

If TS9800 System is used with parts (e. g. actuator, sensor cables, heating devices) that are not produced by Techcon then the warranty is voided.

CONSEQUENTIAL COSTS, SHIPPING AND HANDLING CHARGES: Techcon will not cover any consequential costs caused by system failures. Freight charges must be carried by the owner, except a repair is necessary within the period of warranty.

In all cases, the correctly filled-in decontamination declaration must be sent with the system.

12.2 Return

Each TS9800 Piezo Jet Valve that has been in contact with toxic chemicals or other harmful materials must be decontaminated before being returned to Techcon.

This declaration is necessary even for an unused valve. If the valve was used the liquids which were in contact with the valve need to be listed in the decontamination declaration to Techcon. The signed certificate needs to be fixed on the outside of the transport packing.

If a loaner valve is returned un-clean, it will be sent back to the customer.

In any case, the customer is liable for defects caused by insufficient decontamination. This includes explicitly damage to persons and property.

Each returned system needs to be accompanied by a “status-sheet.” All information about the system must be filled out on this sheet (e. g. system returned for maintenance, for repair, dispensing parameter).

Manufacturer reserves the right to make engineering product modifications without notice.

All returns must be issued with a Returns Authorization number prior to return. Send warranty returns to:

Americas

OK International
10800 Valley View Street
Cypress, CA 90630
USA

Europe

OK International
Eagle Close
Chandler’s Ford Est
Eastleigh
Hampshire
SO53 4NF
United Kingdom

Asia

OK International
4th floor East, Electronic Building,
Yanxiang Industrial Zone, High Tech Road,
Guangming New District, Shenzhen P.R.C



LOCAL DISPENSING SOLUTIONS WORLDWIDE

United States

Techcon Corporate Headquarters
10800 Valley View Street, Cypress, CA 90630 USA
Tel: 1-714-799-9910, Fax: 1-714-230-2303
E-mail: [oemorders@okinternational.com](mailto: OEMorders@okinternational.com)

Europe

Techcon European Corporate Office
Eagle Close, Chandler's Ford Industrial Estate
Eastleigh, Hampshire, SO53 4NF, UK
Tel: +44 2380 489 100, Fax: +44 2380 489 109
E-mail: [europe-orders@okinternational.com](mailto: europe-orders@okinternational.com)

Asia

Techcon/OK International
4th floor East, Electronic Building
Yanxiang Industrial Zone, High Tech Road
Guangming New District, Shenzhen P.R.C.

