

TS8200D Series

Micro-Meter Mix User Guide



TECHCON™



TS8200D Series Micro-Meter Mix

True volumetric measuring, mixing, and dispensing
of 2-component materials



The TS8200D Series Micro-Meter Mix Pump is our dispensing solution for applications involving two-component (2K) materials. The pump is comprised of two individual high-quality progressive cavity (PC) pumps, pulled from our existing PC pump product line, and optimized for 2K dispensing. PC technology will simplify your dispensing process and improve reliability by providing high quality and consistent dispensing over many years in operation.

After reading this guide, we hope you develop a solid understanding of the theory of operation, parts and features, initial set-up and pump integration, assembly and disassembly, product specifications, and maintenance of the TS8200D Series Micro-Meter Mix pump.

Please spend some time going over the material covered in this guide. This guide was written by experts who have spent ample time working with the product. Please follow our experts' recommendations and all provided testing procedures. It is very likely all your questions will be covered in this guide. Nevertheless, if you need further assistance, please do not hesitate to contact our Techcon support team. Detailed contact information is provided on the last page of this document.

From Our Team

Thank you for choosing and putting your trust in our fluid dispensing systems to solve your dispensing needs. Over the years, we have strived to be the brand of choice for customers looking to make processes more efficient, improve industrial hygiene, enhance productivity, and increase/create value. We accomplish this by delivering dispensing solutions that are smarter, cleaner, and with superior accuracy and durability.

Here at Techcon we value your business and will do everything we can to make you a satisfied customer.

Please know that no matter the industry, whether it be: aerospace, military, material packaging, industrial assembly, medical devices, or electronics, you're supported by a team of expert engineers who can solve your toughest manufacturing problems. Therefore, if at any time you experience issues with our product, please do not hesitate to reach us.

We guarantee we will resolve any problems you may encounter to your satisfaction.

We hope to establish a long-lasting relationship.

Thanks again for choosing Techcon



Contents

1. Introduction	4
1.1 Key Features and Benefits	4
1.2 Typical Applications	5
1.3 Configuration Options	5
1.4 Theory of Operation.....	6
1.5 How to Control the Pumps.....	7
2. Technical Specifications for the Micro-Meter Mix System.....	8
2.1 Pump Dimensions.....	9
3. Unpacking & Inspection.....	10
4. Installation	12
4.1 Out of the Box Assembly Instructions.....	12
4.2 Mounting the Pumps	16
4.3 Dispense Fluid Set-Up	16
4.4 Final System Layout.....	18
4.5 Venting and Purging the Pumps.....	18
4.6 Calibrating the Pumps.....	22
4.7 Determining Controller Settings and Final Set-Up.....	22
5. Maintenance and Cleaning.....	26
5.1 Preparations Before Disassembly	27
5.2 Pump Disassembly	28
5.3 Pump Cleaning	31
5.4 Pump Assembly	34
6. Part Numbers and Spare Parts.....	36
7. Troubleshooting	43
8. Appendix A	44
9. Limited Warranty & Contact Information.....	45

1. Introduction

The TS8200D Series Micro-Meter Mix is a precision volumetric mixing and dispensing system for 2-component material. It consists of 2 progressive cavity (PC) pumps integrated in a fluid manifold connected to the static mixing nozzle. Part A and part B of the material is precisely fed by the progressive cavity pump with the correct ratio into the static mixing nozzle to provide accurate mixing and dispensing output. Every component of the pump was designed to the highest tolerances and manufactured to the strictest degree of precision, ensuring world class accuracy and repeatability.

1.1 Key Features and Benefits

- True Volumetric/Positive Displacement technology to achieve +/- 1% variation in dispense output
- High quality mixing to ensure proper material curing
- Continuous Flow with adjustable flow rate to provide continuous dispensing process for efficient operation
- Independent of pressure and viscosity change to ensure accurate and precise results
- Suckback action to prevent material dripping
- Quick and easy cleaning to reduce down-time



1.2 Typical Applications

- Bonding
- Glob-Top Potting and Encapsulation
- Potting of Electronic Components
- Battery Pack Sealing
- Thermal Paste Dispensing
- Filling

1.3 Configuration Options

Each PC pump is available in three different sizes. The size is determined by the stator and rotor selection.

- 100 Series Stator & Rotor
 - 0.012 ml/rev per pump
 - Minimum dispense volume: 0.012ml per pump
 - Flow rate: 0.12 – 1.21 ml/min
- 200 Series Stator & Rotor
 - 0.055 ml/rev per pump
 - Minimum dispense volume: 0.055ml per pump
 - Flow rate: 0.65 – 6.90 ml/min
- 300 Series Stator & Rotor
 - 0.080 ml/rev per pump
 - Minimum dispense volume: 0.080 ml per pump
 - Flow rate: 0.78 – 8.12 ml/min



Note: The TS8200D may be configured in 1 of 6 different pump type configurations.

- TS8200D-100-PS-SYS – Pump A: 100 Series, Pump B: 100 Series
- TS8200D-200-PS-SYS – Pump A: 200 Series, Pump B: 200 Series
- TS8200D-300-PS-SYS – Pump A: 300 Series, Pump B: 300 Series
- TS8200D-2100-PS-SYS – Pump A: 200 Series, Pump B: 100 Series
- TS8200D-3100-PS-SYS – Pump A: 300 Series, Pump B: 100 Series
- TS8200D-3200-PS-SYS – Pump A: 300 Series, Pump B: 200 Series

Tip: Please reference Appendix A for information on flow rate and ratio capabilities with the different pump type combinations. Other information available: smallest shot size, combined flow rate references.

1.4 Theory of Operation

The TS8200D Series Micro-Meter Mix pump dispenses fluid with a positive displacement action using progressive cavity technology. Fluid is introduced into the pump through the fluid inlet and begins to occupy the empty space that makes up the upper valve body. The stator and rotor form a perfect seal preventing any material from flowing beyond their mating point. As the rotor rotates, the fluid is allowed to flow from one sealed cavity to the next, enabling precise volumetric deposits of material. During initial set-up, continuously purging of material will be required to fill the fluid manifold's fluid path before any actual metering may be performed. Precise metering quantities of part A and part B will be deposited at the valves output end. A static mixing nozzle is required to perform the actual mixing of the 2-part material. The output is driven by a 24 VDC encoder motor. Shearing of the fluid is achieved by reverse Z-motion (tip retraction).

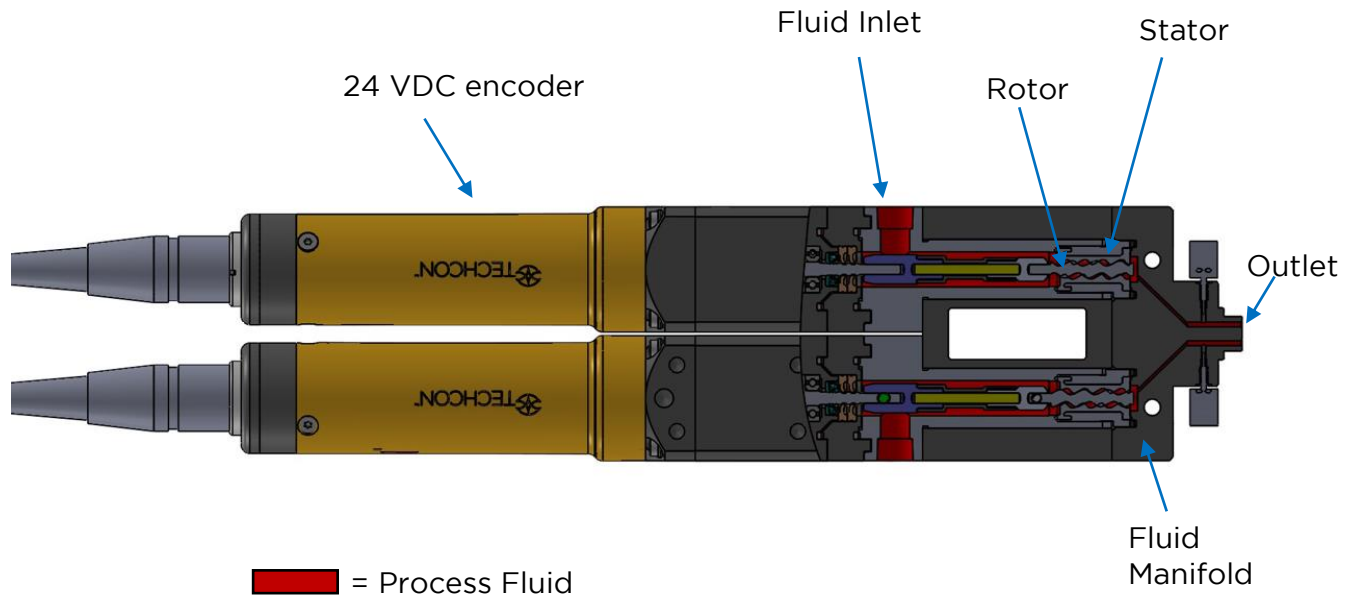

1.5 How to Control the Pumps

The TSS8200D Micro-Meter Mix pump must be integrated with the Techcon TS580D-MM Series controller. The TS580D-MM allows users to make the most use out of their dispensing pump. Controller features include dispensing in volume, weight, or timed mode, quick and simple programming to dispense lines, access to over 50 different memory locations for quick profile change, and remote access & control of programs via ethernet.





2. Technical Specifications for the Micro-Meter Mix System

Size:	314 mm L x 69 mm W x 34 mm D 12.4" L x 2.7" W x 1.3" D				
Weight:	1.24 kg/2.74 lb.				
Motor:	24V DC, incremental encoder				
Flow rate:					
100x100	200x200	300x300	200x100	300x100	300x200
0.24- 2.42ml/min	1.29- 13.80ml/min	1.56- 16.24ml/min	0.77- 8.11ml/min	0.90- 9.33ml/min	1.43- 15.02ml/min
Dispensing Volume Per Revolution per Pump					
100x100	200x200	300x300	200x100	300x100	300x200
.012 ml	.047 ml	.08 ml	.012 ml for -100 .047 ml for -200	.012 ml for -100 .08 ml for -300	.012 ml for -100 .08 ml for -300
Repeatability:	+/- 1% per pump				
Dispense Accuracy	> 99%				
Fluid inlet pressure Maximum	Up to 2 bar (30 psi) for viscosity of 1,000 cps or less, up to 5.5 bar (80 psi) for viscosity greater than 1,000 cps				
Fluid inlet type:	1/8" NPT				
Mixing Nozzle:	K-type, Standard Bayonet				
Mounting:	M4 x 35MM, SHC, S.S				
Wetted Parts:					
	Stator Housing	Anodized Aluminum			
	Rotor:	Carbide			
	Stator:	PFE			
	Flex Coupling:	Stainless Steel, Polyolefin			
	Shaft Seal Block	Delrin			
	Manifold Plugs	Delrin			
	Manifold Gaskets	Viton			
	Pump O-rings:	BUNA N			
	Vent seals:	Fluorsilicone			
	Vent Screws:	Stainless Steel			
	Fluid inlet fittings	UHMWPE, NYLON			
Operating Temperature	10 - 40°C (50 - 104°F)				
Fluid Temperature	10 - 40°C (50 - 104°F)				
Storage Conditions	10 - 40°C (50 - 104°F)				
Fluid Viscosities	1 - 300K Cps (m.Pa.s)				

*2 bar self-sealing is for fluid with viscosity of 1000 Cps or lower. The pump can handle up to 5.5 bar for 300K Cps viscosity fluid.

**Accuracy measurements are taken for one complete revolution. Absolute deviation in volumetric dispense accuracy exist for incomplete revolutions and may also occur for certain dispensing fluid.

2.1 Pump Dimensions

Units = mm

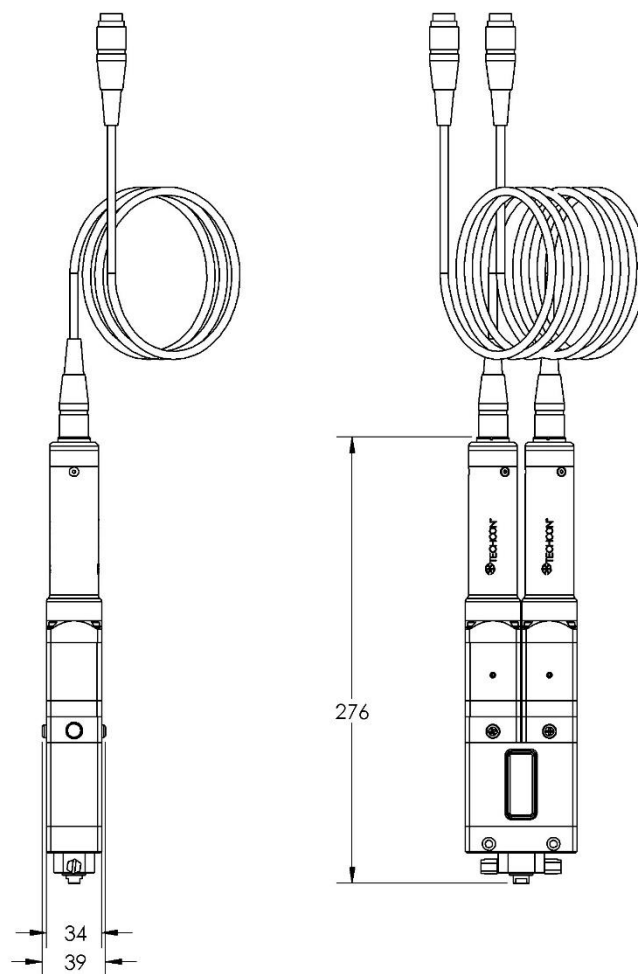

3. Unpacking & Inspection

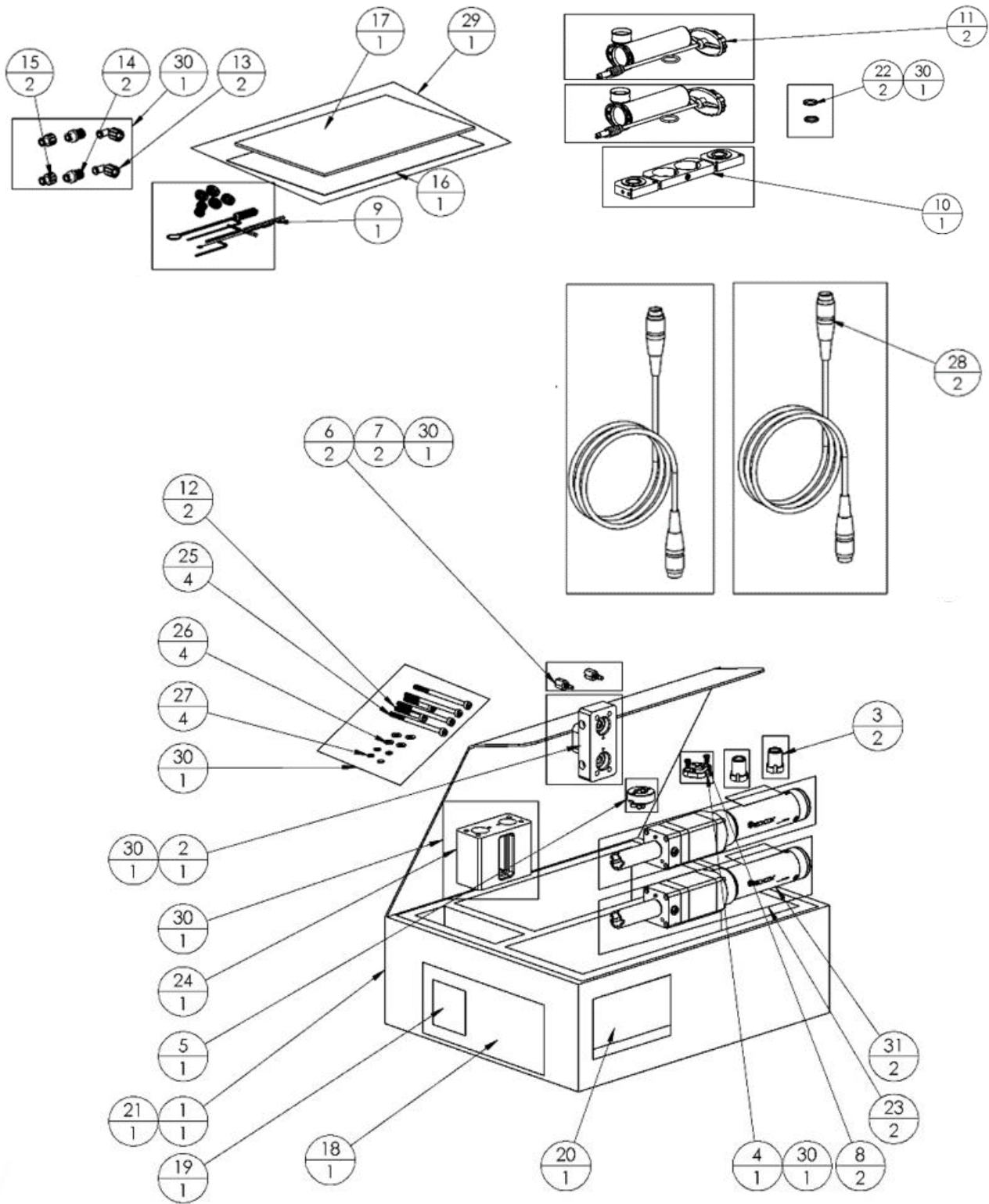



The pump includes the following items:

ITEM NO.	PART NUMBER	DESCRIPTION	QTY.
1	7000-7300	BOX, 12 X 10.0 X 4.25, METER MIX	1
2	7509-1150	FLUID MANIFOLD,K-TYPE NOZZLE, 1:1 RATIO	1
3	8100-100-002 8100-200-002 8100-300-002	REPLACEMENT STATORS, PC PUMP *Part Number based on Pump configuration	2
4	7509-1160	LOCKING PLATE, K-TYPE NOZZLE	1
5	8200D-000-001	CALIBRATION ADAPTOR	1
6	7509-1190	PLUG SCREW, FLUID MANIFOLD	2
7	3300-0662	O-RING, 3MM ID X 1MM CS, EPDM	2
8	2800-1027	M3x6mm LG, SHC,S.S. LOW PROFILE	2
9	8100-CLEANKIT- MMM	CLEANING KIT, MMM, PC PUMP	1
10	TS8200D- SYBRACKET	SYRINGE BRACKET, METER MIX	1
11	A0100488-2	700 SERIES,30cc RECEIVER HEAD ASSY	2
12	2800-1031	SCREW, M4 x 35MM, SHC, S.S	2
13	TSD931-81B	ELBOW 90 DEG. WITH LUER LOCK, BLACK NYLON	2
14	TSD931-96	FEMALE LUER WITH 1/8 NPT THREAD	2
15	TSD931-82B	MALE ADAPTER WITH LUER LOCK, BLACK NYLON	2
16	7000-7320	USER GUIDE, METER MIX	1
17	7000-7310	QUICK SETUP INSTRUCTIONS SHEET, METER MIX	1
18	7000-4340	LABEL, PACKAGING, VALVE	1
19	4100-0059	LABEL, LEAD FREE RoHS COMPLIANT(500/ROLL)	1
20	7000-3640-AW	ARTWORK, STANDARD PACKAGE LARGE LABEL	1
21	1400-0280	FOAM, INSERT, METER MIX	1
22	3300-0656	GASKET, 1/2" ID X 5/8" X 1/16 W, VITON	2
23	1400-0187	BAG, 12" x 5", 2 mil POLY BAG	2
24	7509-1460	HOUSING PUMP,MICRO-METER MIX	1
25	2800-1034	M4X70 LG, Stainless Steel Socket Head Screw	4
26	2800-0543	Washer, M4, Flat, S.S	4
27	2800-0518	WASHER, M4, SPLIT LOCK, S.S	4
28	8100-100-007-MC	REPLACEMENT CABLE ASSEMBLY ,PC PUMP	2
29	P9500010	BAG, FLAT PE, CLEAR, 6 X 8 X 4 MIL	1
30	1400-0022	BAG,3 X 5,2 MIL,POLYETHYLENE,ZIPLOCK	5
31	7509-9421 7509-9422 7509-9423	ASSEMBLY, PUMP,MICRO-METER MIX *Part Number Based on Pump Configuration	2
32	8200D-PS	Optimal Pressure Sensor (optional)	1

4. Installation

4.1 Out of the Box Assembly Instructions

Required tools:

- 8mm (5/16") wrench or crescent wrench or flat head screwdriver (for mounting pressure sensors)
- 3.0 mm hex wrench (for manifold screws)
- 2.5 mm hex wrench (for mounting calibration adaptor)
- 2.0 mm hex wrench (for mounting K-type nozzle locking plate)
- Dispensing Fluid (material to be used or cleaning/lubricating fluids)

Warning! Do not dry-assemble the rotor and stator. Excessive friction between dry components may damage stators and effect pumps performance.

***Do not use water.** Using water may damage the pump. Recommend using conditioning fluid for cleaning.

1. Apply the dispensing fluid or any appropriate lubricant compatible with the dispensing fluid to the surface of the rotor.
2. Wet the stator opening by squeezing a small amount of the dispensing fluid or any appropriate lubricant that is compatible with the dispensing fluid.



3. Screw the stator onto the rotor in a clockwise direction, align the 4 tabs of the stator with the 4 notches of the stator housing, and push in the stator to lock it into place with the stator housing.

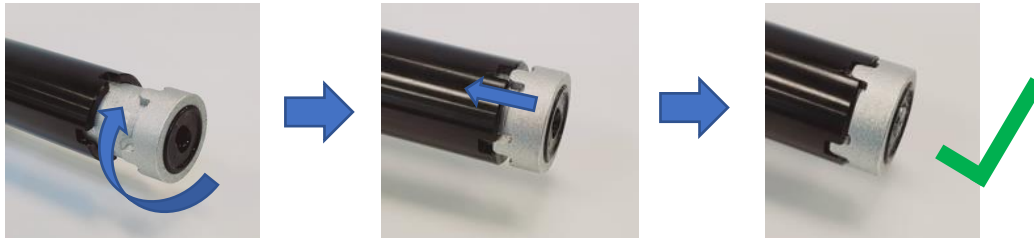

4. Plug and thread in the motor cables.

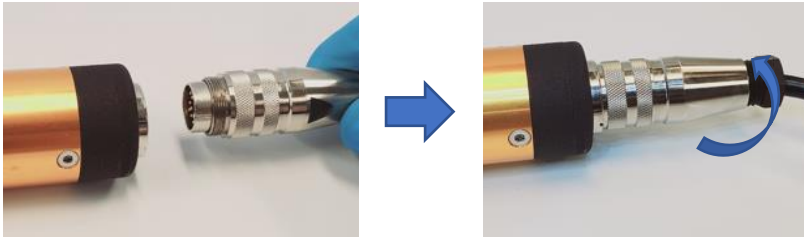

5. Insert pump assemblies into the pump housing.

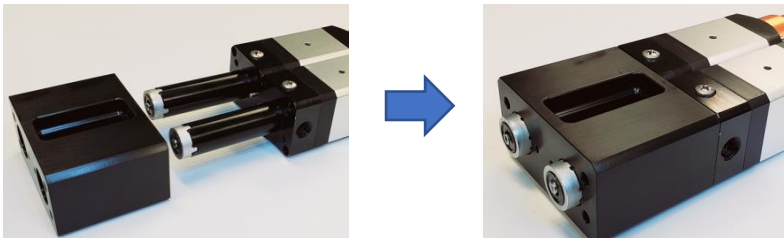

6. Make sure that the high-pressure seals sit and fit properly along the groove located inside the manifold.

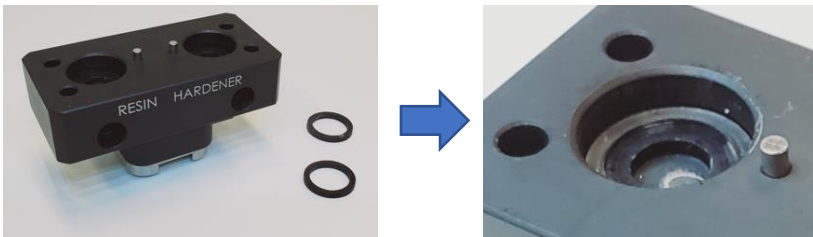

7. Align the manifold with the now-assembled pump and pump housing. The engraved labels “RESIN” and “HARDENER” should be facing you. Insert and fasten four (4) 3.0 mm hex screws with lock washers in the order shown in the image below. Make sure the two now-assembled pumps are vertically symmetrical and not flaring outwards. Make sure there are no gaps or any visible light between pump housing and mating parts. If there are issues relieve tension on the screws and tighten evenly. Reference the image below for recommended fastening order.

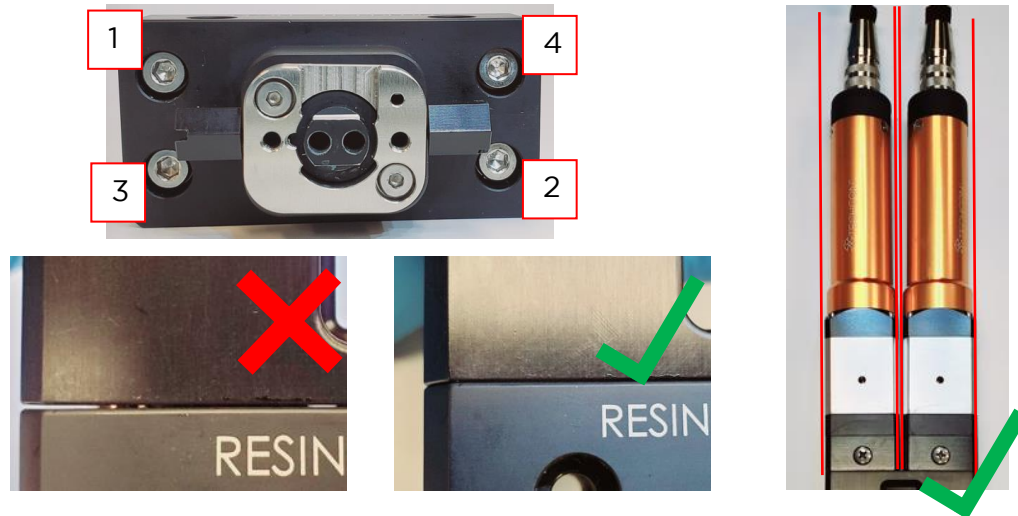

8. Install fluid inlet fittings.

There are several different fluid inlet fittings available. The fluid inlet fitting required will depend on the fluid reservoir option you select. In the picture below, we use 1/8 NPT x luer lock elbow. Reference the “Accessories” section for information on fluid inlet fittings. It is recommended that Teflon tape be applied to the thread of the fluid inlet fitting prior to installation.

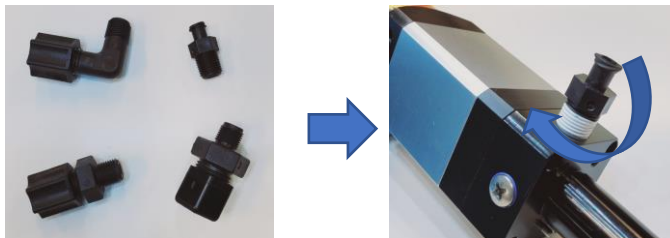

9. Mount pressure sensors (optional feature)

TS8200D is available with sensors for monitoring dosing pressure. With this feature you are able to keep closer track of any output pressure changes caused by factors other than viscosity, such as premature curing/hardening of material or obstructions preventing the flow of material.



- a. Remove both fluid manifold plug screws and O-rings.
- b. Mount sensors. Note: If the sensors are missing O-rings, use the O-rings from the plugs.
- c. Screw the sensors by hand and use 8.0 mm wrench, crescent wrench, or flat head screwdriver for the final tightening.

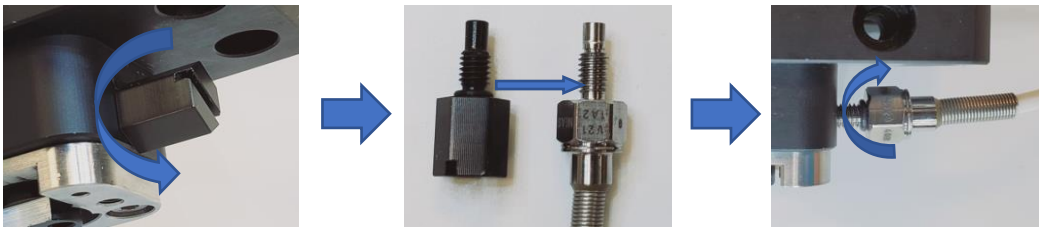

Tip: To avoid cable “curling,” do not install sensors to the controller before fastening the sensors to the pump.

Warning! The surface of the sensors is extremely sensitive. Therefore, take extra caution when handling these sensors and avoid hitting them against other surfaces.

10. Install Calibration Adaptor

The calibration adaptor is required whenever calibration is performed, when a new fluid is introduced, when the valve is disassembled & reassembled, or when the stators or rotors are changed. Connecting calibration adaptor can protect the TS8200D from having direct contact with the material as it exits the pump.

- a. Mount the 1:1/2:1 K-type Nozzle Locking Plate and use a 2.0mm hex wrench to fasten screws into place.
- b. Mount the calibration adaptor and use a 2.5mm hex wrench to fasten screws into place.
- c. Make sure that the calibration adaptor rest evenly against the nozzle locking plate.

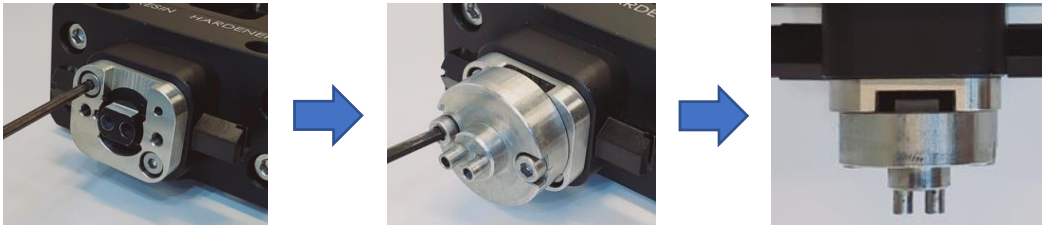

4.2 Mounting the Pumps

There are two mounting holes for M4x35mm SHCS (screws provided with the pump). Use a 3.0mm hex wrench to fasten screws into place.

Note: If mounting to a TSR series dispensing robot, you will require 7506-0280 mounting plate. The valve may be mounted using holes marked with a red circle.

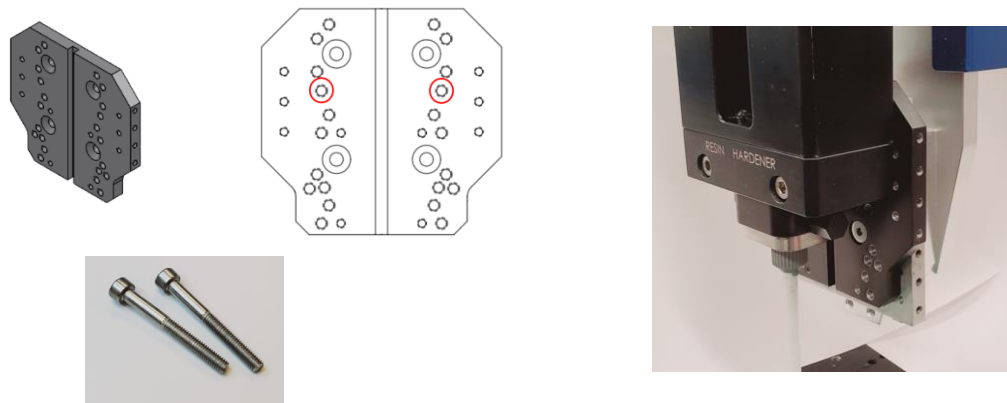

4.3 Dispense Fluid Set-Up

Warning/For your safety:

- Follow the safety guidelines outlined by the manufacturer for instructions on handling the process fluid.
- Do not overtighten fittings. Doing so may damage pump housing components.
- Do not use water for priming or cleaning the pump. Doing so may damage the pump.
- Do not run the TS8200D without material. Excessive friction between dry components may lead to pump damage.

You will need the following items:

- Phillips head screwdriver (not included)
- Fluid supply components and fluid inlet fittings
- Process Fluids

1. Prepare process fluids and fluid supply. The fluid supply may be either syringes or a fluid reservoir. Reference “Accessories” section for information on available fluid supply solutions.

Tip: “Degassing” the fluid is recommended. Trapped air will contribute to dispense volume variations.

Warning! Do not pressurize the fluid supply at this time!

2. Inspect and confirm fluid vent screws are present and well fastened on both the front and back of the pumps.

Tip: Avoid over tightening vent screws. Over tightening may lead to tears to the vent seal O-ring.

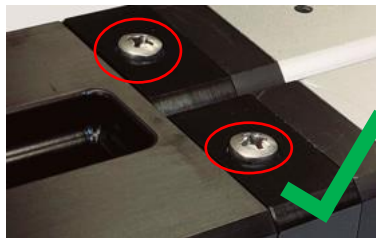

3. Connect the fluid supply to the fluid inlet of the pump. If using a fluid reservoir, reference the “Accessories” Section for information on compatible fluid lines. Make sure the resin is connected to the pump with the “RESIN” label and the hardener is connected to the pump with the “HARDENER” label.

Warning! Do not pressurize the fluid supply at this time!

4. If the pump is not already mounted or placed in the “up-right” vertical position, please do so at this time.
5. Install any fluid supply accessories. Reference “Accessories” section for information on fluid supply accessories.
6. Install the TS580D dispensing controller.

4.4 Final System Layout

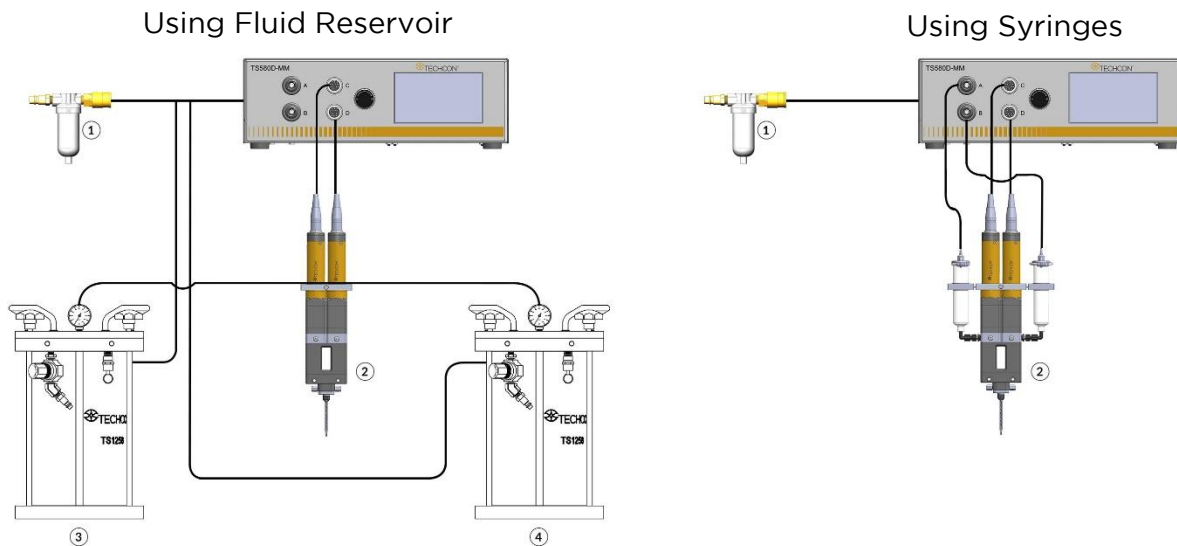

1. Air Filter, 2. Pump, 3. Pressure Tank, 4. Pressure Tank

4.5 Venting and Purging the Pumps

Venting and purging the pumps is recommended before placing them into operation. Failure to vent and purge during the initial setup may lead to dispensing issues.

- a. Begin to pressurize the fluid supply.

Warning! Make sure the fluid supply pressure is set very low. A good rule is to begin pressurizing the fluid starting from 0 psi. Reason: Higher pressures may cause low viscosity fluids to spray from the output when purging or from the pump housing if the pump is incorrectly assembled.

- b. Set the fluid pressure to around 0.3 bar (5 psi). The fluid pressure will depend on the viscosity of the material. For this sample setup, we are assuming low viscosity less than 1000 cps (mPa-s) is being used on both the left and right pump.

Tips: Low viscosity (1 - 2000 cps)	Pressure range 1 - 10psi
Medium viscosity (2000 - 30,000 cps)	Pressure range 10 - 20 psi
High viscosity (30,000 cps +)	Pressure range 20 - 80 psi

c. Inspect the seals for leaking

From top to bottom inspect:

1. Front and back vent port seals
2. Stator housing top seal
3. Fluid inlet fitting seal
4. Pump housing top seal
5. Pump housing bottom seal
6. Pump output seal

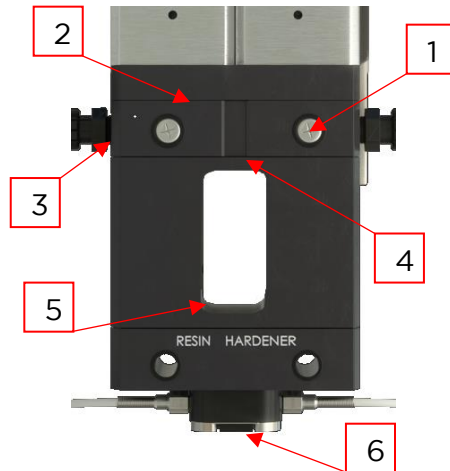

If there is any leakage, adjust the tension on the screws and inspect the O-ring seals. Reference disassembly section of user guide for additional information.

d. Purging and Venting “RESIN” – Pump 1

- i. Place a clean towel or a container under the pump.

Tip: Never use the same cleaning towel for both process fluids. Mixing the fluids may lead to undesired chemical reactions.

ii. To purge the resin through the manifold:

1. Navigate to the Home page.



2. Unlock the unit by clicking lock icon.  Default password = 0000.

3. Select the Purge Pump 1 icon. 

Note: Purge Pump 1 icon will dispense the resin at a safe speed for initial priming of the pump.

4. Press the foot switch.
5. Allow the fluid to flow from the manifold until a steady stream of air free material is observed.

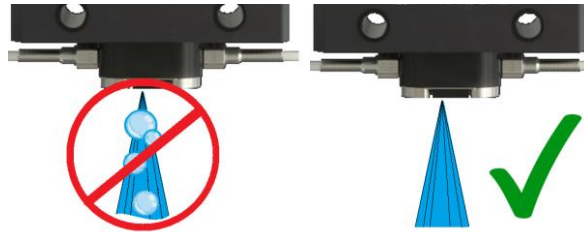

6. Release the foot switch.
 7. We are now done purging pump 1.
- iii. To vent the resin:
1. Have a cleaning towel or container under the pump ready to catch material
 2. Using a Phillips head screwdriver, loosen front vent screw by turning in the counterclockwise direction. Loosen screw in 1 revolution increments. At around the 6th - 7th revolution, you should begin to see material seep out. Allow material to escape until no more air bubbles are observed.



Warning: Do not loosen to more than 8 complete revolutions. Doing so will unfasten the screw allowing pressurized material to spray out.

3. Fasten the venting screw. Avoid over tightening the screw.
Over tightening may lead to tearing of the vent seal O-ring.
- e. Purging and Venting “HARDENER” - Pump 2
- i. Place a clean towel or a container under the pump

Tip: Never use the same cleaning towel for both process fluids. Mixing the fluids may lead to undesired chemical reactions.

ii. To purge the hardener through the manifold:

1. Navigate to the Home page.



2. Unlock the unit by clicking lock icon.



Default password = 0000.

3. Select the Purge Pump 2 icon.



Note: Purge Pump 2 icon will dispense the hardener at a safe speed for initial priming of the pump.

4. Press the foot switch

5. Allow the fluid to flow from the manifold until a steady stream of air-free material is observed.



6. Release the foot switch.

7. We are now done purging pump 2.

iii. To vent the hardener:

1. Have a cleaning towel or container under the pump ready to catch material

2. Using a Phillips head screwdriver loosen front vent screw by turning in the counterclockwise direction. Loosen screw in 1 revolution increments. At around the 6th to 7th revolution you should begin to see material seep out. Allow material to escape until no more air bubbles are observed.



Warning: Do not turn more than 8 complete revolutions. Doing so will unfasten the screw allowing pressurized material to spray out.

3. Fasten the venting screw. Avoid over tightening the screw. Over tightening may lead to tearing of the vent seal O-ring

4.6 Calibrating the Pumps

Before we can begin using the TS8200D Micro-Meter Mix, we will need to calibrate each pump. Go to the TS580D Controller User Guide for calibration instructions. Return here once calibration has been completed.

Tips: During the calibration process, it is recommended that you collect and weigh a sample size of at least 5 samples for the MEDIUM weight entry to confirm the pumps are dispensing consistently. If air bubbles are still present, return to the previous section to vent and purge. Once consistency is confirmed, you will only need to weigh and enter one data entry when prompted to.

4.7 Determining Controller Settings and Final Set-Up

- iv. Determine and enter the correct settings and ratio for Resin (Pump 1) and Hardener (Pump 2). Refer to TS580D Controller User Guide for instructions on settings up: forward run settings, reverse run settings, ratio settings, and dispense mode settings.

v. Remove calibration adapter.

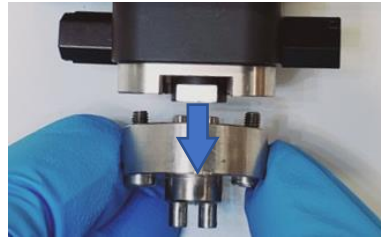

vi. Install dispense adaptor required for corresponding static mixing nozzle

Note: TS8200D is compatible with several different types of static mixing nozzles. Reference “Part Numbers and Spare Parts” section for additional information.

Required tools:

2.0 mm hex wrench

- If using 1:1/2:1 bayonet socket type
The static mixing nozzle can be mounted directly onto the pump using the already installed 1:1/2:1 K-type nozzle locking plate
 - Align the holes and rotating cap of the mixing nozzle with the holes of the fluid manifold and “keyed” entry of the base plate adaptor.
 - Insert the nozzle and make sure it rests evenly with the base of the fluid manifold. Lock into place by rotating the mixing nozzle’s rotating cap counterclockwise.
 - Pull on the nozzle to confirm it is securely locked into place.

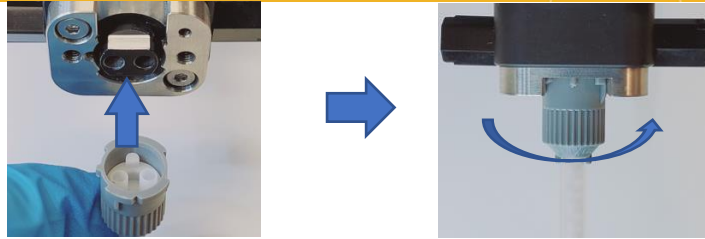

- If using a 4:1/10:1 bayonet socket type

1. Remove bayonet socket base plate adapter.

2. Confirm 4:1/10:1 base plate adapter has x2 O-ring seals.



3. Mount 4:1/10:1 base plate adapter followed by the bayonet socket base plate adapter.

- Align the holes and rotating cap of the mixing nozzle with the holes of the fluid manifold and “keyed” entry of the base plate adaptor.
- Insert the nozzle and make sure it rests evenly with the base of the fluid manifold. Lock into place by rotating the mixing nozzle’s rotating cap counterclockwise.
- Pull on the nozzle to confirm it is securely locked into place.



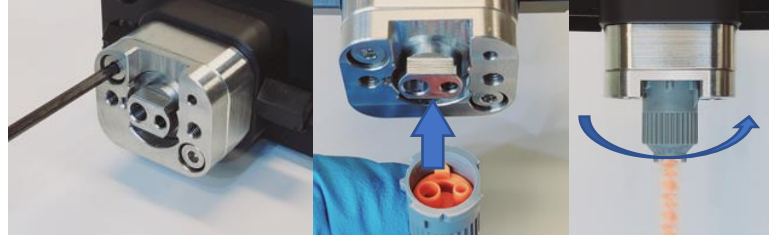

- If using a bayonet mixing nozzle:

1. Remove bayonet socket base plate adapter.
2. Confirm bayonet base plate contains x2 O-rings
3. Install bayonet base plate adaptor.
4. Twist and lock.
5. Pull on the nozzle to confirm it is securely locked into place.

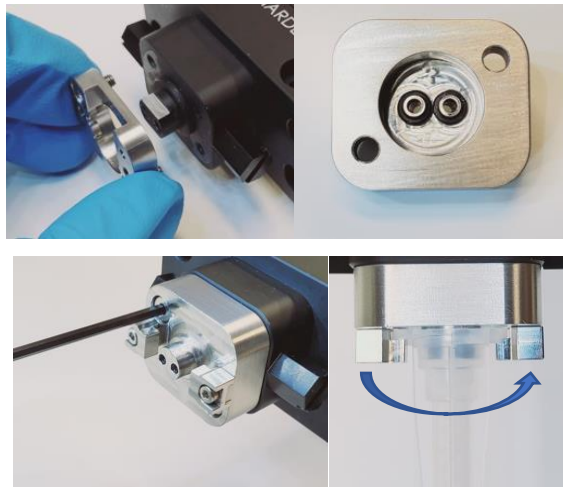

The pump is now ready for use.

Tips:

1. Viscosity can affect the rate of dispense even at a set motor speed. Dual component media usually have different viscosity for part A and part B. If



the viscosity difference between part A and B is significant, then the output pressure of one material vs the other will differ. Factors that will need to be kept in mind will be a suitable mixing nozzle, flow rate, and appropriate material pressurization. You may find the need for a secondary pressure regulator.

2. Avoid excessively high reverse volumes and flow rates. If reverse is too high, mixed material may enter the dispensers, causing them to react with each other.
3. Based on your pump type configuration e.g., 100x100, 200x100, 300x100, etc. the flow rate resolution (minimum and maximum flow rate range) at a given ratio will be different. Reference Appendix A for additional details on flow rate vs ratio specs for a given pump type.
4. Keep in mind the pot life of the material. Leaving mixed material during breaks or overnight may render the mixing nozzle unusable upon start-up. One possible solution to extend the life of mixing nozzles is to rinse (fill completely) the mixing nozzle with one of the two materials. Doing so may prevent the two components from reacting and curing. Please note this solution is not suitable for all environments or for extended breaks. This solution may not be applicable to all materials.

5. Maintenance and Cleaning

Maintenance and cleaning of the TS8200D is required whenever one of the following scenarios occur:

1. The process fluids are changed
2. Dispensing data is no longer consistent
3. Process fluid does not flow or cures in the fluid manifold

It is recommended that the user regularly inspect dispense data to assess whether it is time for cleaning. Components that will wear over time and that will require replacement at regular intervals include stators, rotors, and seals.

It is recommended that a complete disassembly, full cleaning, and inspection of all parts be performed at least once per month

Required tools for disassembly and assembly:

- 8 mm (5/16") wrench or crescent wrench or flat head screwdriver (for mounting pressure sensors)
- 3.0 mm hex wrench (for manifold screws)
- 2.5 mm hex wrench (for mounting calibration adaptor)
- 2.0 mm hex wrench (for mounting K-type nozzle locking plate, removing stator housing)
- 1.5 mm hex wrench (for removing flex coupling set screw)
- 1.3 mm hex wrench (for removing rotor set screw)
- Phillips #2 screwdriver

5.1 Preparations Before Disassembly

1. Flush (purge) all material from the pump with cleaning fluid. The recommended purging fluid is Techcon 7305XCON dispensing conditioner. The conditioner removes the majority of the material residue from the material path and conditions the pump for future use.

Procedure:

- Release material feed pressure.
- Disconnect material from the pump.
- Remove dispensing tip.
- Install a barrel of dispensing conditioner to the pump inlet and set the air pressure to 15 psi
- Set the controller to Purge Pump 1 or Purge Pump 2 (selection based on pump being cleaned).
- Press the footswitch to let the pump run until the conditioner is the only material coming out of the pump outlet.



- Release the footswitch to stop the pump.
- 2. Shut-off the air supply to the pumps.
- 3. Stop fluid supplies to the pumps and disconnect fluid supply tubing.
- 4. Unmount the TS8200D.
- 5. Disconnect motor connections from the pump to the controller.
- 6. Remove mixing nozzle.

5.2 Pump Disassembly

1. Use a 2.0 mm hex wrench to remove the mixing nozzle adaptor.



2. Use an 8 mm (5/16") wrench or crescent wrench to remove pressure sensors or use a flat head screwdriver to remove manifold plugs. Replace plug screw O-rings if damaged.

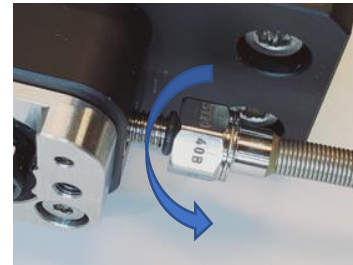

Tips:

- The surface of the sensors is extremely sensitive. Therefore, take extra caution when handling these sensors and avoid hitting them against other surfaces.
 - Label sensors such that the same sensor is mounted in the same location upon reassembly
3. Remove fluid inlet fitting.
 4. Use a Phillips #2 screwdriver to remove x4 vent screws and vent seal O-rings. Replace O-rings if damaged.

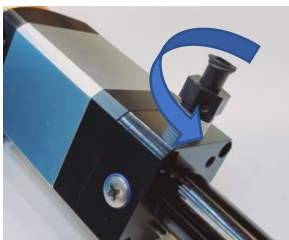

5. Use a 3.0 mm hex wrench to remove four (4) hex screws. Separate the fluid manifold, pump housing, and pump assembly.
6. Remove and inspect manifold gaskets for any wear and tear. Replace if needed.
7. Remove pump housing.

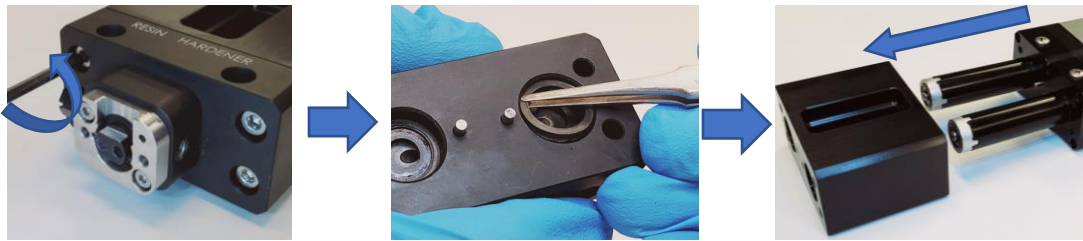

8. Removing the stators

1. Connect the pump to the controller. Using Purge mode, press the footswitch to run the pump. The stator should begin to unwind.
2. Once the stator has cleared the four (4) locking notches, manually rotate the stator in the counterclockwise direction to remove the stator

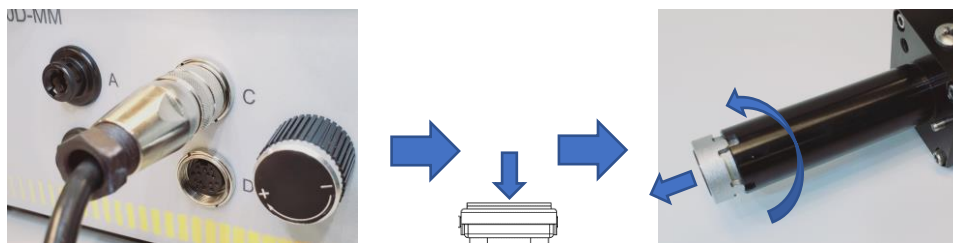

9. If not done so already, use a 2.0 mm hex wrench to remove four (4) stator housing hex screws and pull-out stator housing

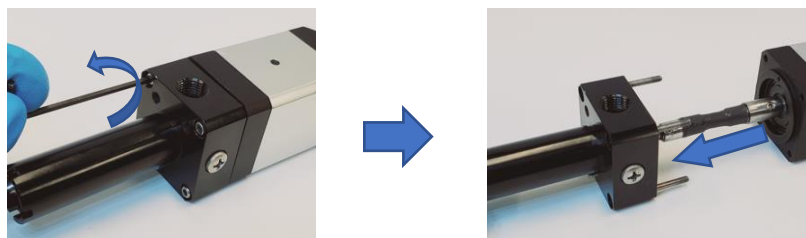

10. Remove and inspect upper valve O-ring for wear and tear. Replace if required.



11. Use a 1.3 mm hex wrench to remove rotor set screw.

Warning: Only perform this step if you plan to switch to a different pump type, e.g., 100, 200, or 300 series.

Tip: When re-installing the set screw, it is recommended that a low strength thread locking fluid be used to hold the set screw in place, such as Loctite 222.

12. Use a 1.5 mm hex wrench to remove flex coupling.

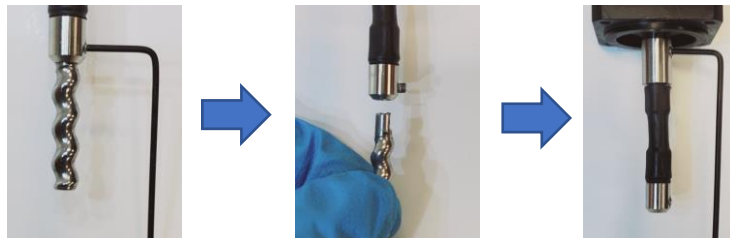

13. Remove the shaft seal block and inspect shaft seal. Replace shaft seal if worn.

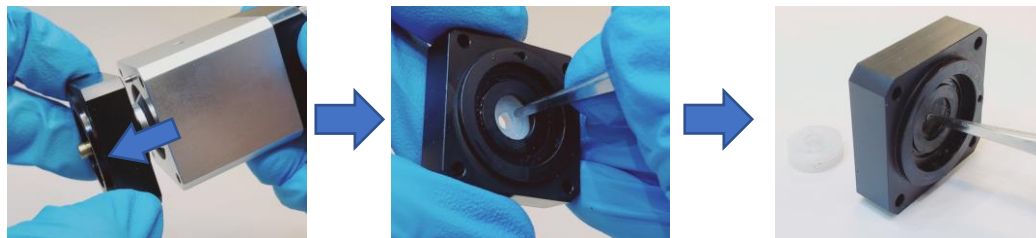

14. Inspect pump O-ring seal and cup seal on the bearing block assembly for wear and tear. Replace if needed.

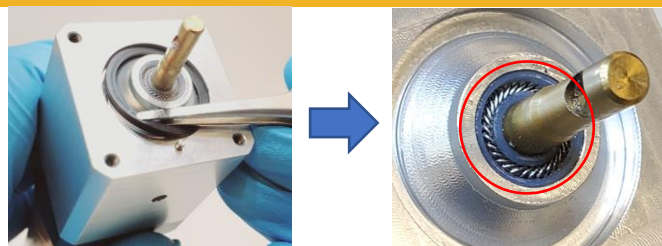

15. Use a 2.0 mm hex wrench to remove four (4) hex screws holding together the motor mounting plate and the bearing block assembly.

16. Inspect and confirm the area that houses the motor coupling is clean and free of any process fluids.

17. Inspect coupling disc. Replace if worn.

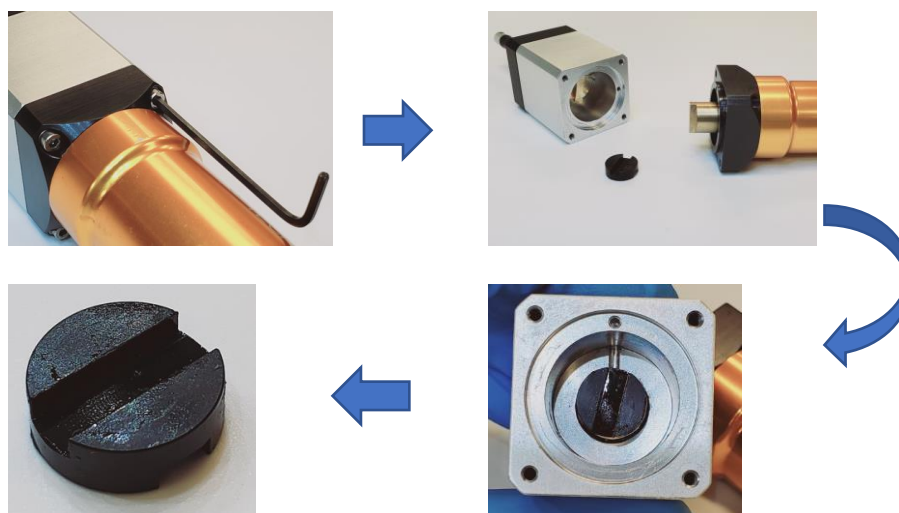

5.3 Pump Cleaning

Refer to product specifications for compatible solvents to use to clean wetted parts.

Recommended Cleaning Tools

1. Cleaning Tools included with cleaning kit
 - a. Brush, Small, 0.15" (3.8 mm)
 - b. Brush, Large, 0.45" (11.4 mm)
2. Cotton swabs
3. Scrapping spatula
4. Fine point tweezers
5. Cleaning towels

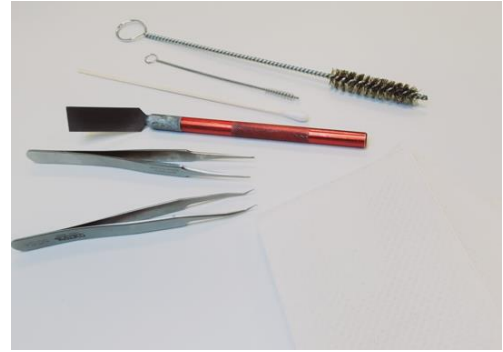

Pump Cleaning Process

1. Use cleaning towels to remove excess material from the surface of all wetted parts.

Tip: Never use the same cleaning towel for both process fluids. Mixing the fluids may lead to undesired chemical reactions.

2. Use tweezers to remove O-rings and to remove dried/hardened material from the side walls of the fluid housings.
3. Use scrapping spatula to remove any cured or dried material stuck to the stator housing's side walls, fluid manifold, or to the base of the shaft seal block.

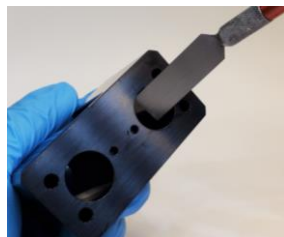

4. Use the large brush to remove all remaining residue from stator housing side walls.

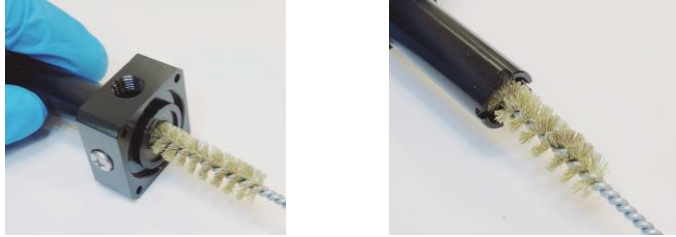

5. Use cotton swabs to remove material stuck to the base of the shaft seal block, fluid manifold, and stator housing.

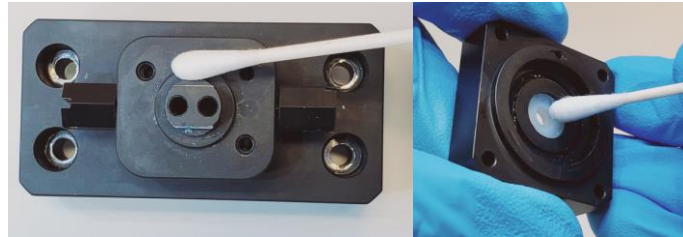
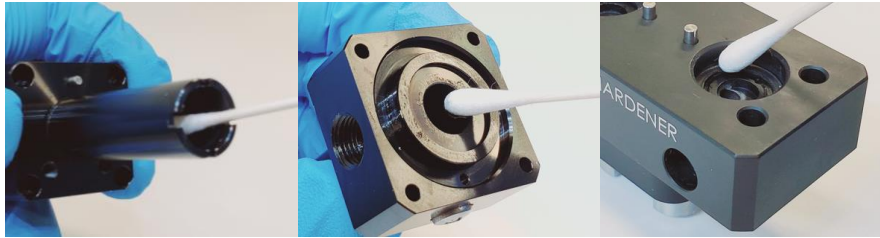

6. Use the small brush to clean fluid path channels of the manifold, fluid inlet openings, vent screw openings, calibration adaptor, and other nozzle adaptor openings.





7. Additional cleaning that may be performed:
 - a. Bathe parts in compatible cleaning fluid overnight
 - b. Ultrasonic washing
 - c. Use of shop air to remove excess material

5.4 Pump Assembly

The steps to assemble the pump are outlined in the previous section in the reverse order.

Things to keep in mind during assembly:

1. Check all fastening screws and connections to ensure they are securely tightened, re-tighten if needed.
2. Check and replace all parts that show signs of wear and tear. This includes seals, stators, rotor, or fluid inlet fittings.
3. If you replace the rotor or remove the flex coupling, make sure to apply low strength threadlocker to the set screws.



4. Make sure to apply process fluid or any appropriate lubricant compatible with the process fluid to the exposed portion of the rotor and stator surface.

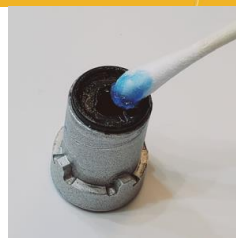

5. Reference the installation procedure for instructions on how to initialize your pumps.
6. Inspect the valve for leaking when the process fluid is re-introduced.

6. Part Numbers and Spare Parts

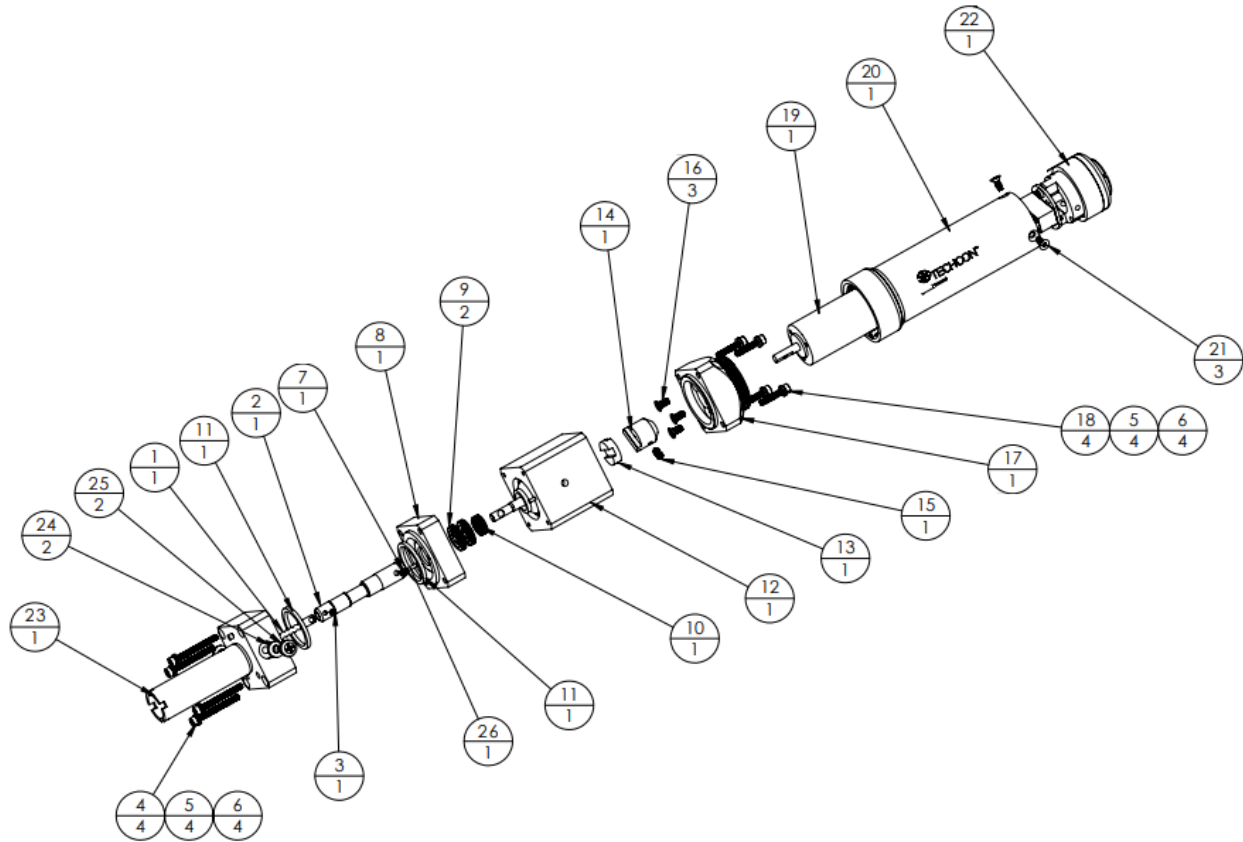

Item #	Part Number	Description	Item #	Part Number	Description
1	7509-0120	Rotor 2.5 mm Pitch (100 Series)	13	7509-0960	Coupling Disc
	7509-0530	Rotor 5.0 mm Pitch (200 Series)	14	7509-0950	Coupling Half Top
	7509-0820	Rotor 6.5 mm Pitch (300 Series)	15	2800-0903	Set Screw, M3 x 0.5mm x 6MM LG, S.S
2	7509-9430	Flex Coupling	16	2800-0901	Screw, M3 x 6mm LG, FH, PHIL, MACH, S.S
3	2800-0836	Set Screw, M2.5 x 3mm LG, Socket, Cup, S.S	17	7509-0980	Motor Mounting Plate
4	2800-1019	Screw, M2.5 x 25mm LG, SHC, S.S	18	2800-0897	Screw, M2.5 x 14mm LG SHC, S.S



5	2800-0295	Washer, M2.5, Lock, Medium, S.S	19	2600-0185	Motor, 24 VDC, Encoder, 83:1 Gear Reduction
6	2800-0917	Washer, #4, 0.115 IDx0.209 OD, 0.024 THK, S.S	20	7509-0340	Motor Cover
7	2800-0688	Set Screw, M3 x 4mm LG, S.S	21	2800-0900	Screw, 4-20 x ¼" Thread Forming, S.S
8	7509-0970	Shaft Seal Block	22	7509-9400	Assy, Motor Connector
9	7509-0990	Shaft Seal	23	7509-1450	Stator Housing
10	3300-0353	Cup Seal, UHMW Jacket, S.S Spring	24	3300-0696	Vent Seal, Washer, #8-.15" ID x .31" OD x.52 THK, Fluorosilicone
11	3300-0690	O-Ring, Square, ¾" ID x 7/8" OD X 1/16 W, BUNA N	25	2800-0431	Vent Screw, M4 x 8mm LG, PAN PHIL, MARC, S.S
12	7509-9340	Bearing Block Assembly, FA	26	3300-0595	PIN, DOWEL, M1.5 DIA x 5mm LG, S.S

Pump Motor Cables

Part Number	Description
8200D-000-002	Cable Assembly, PC Pump

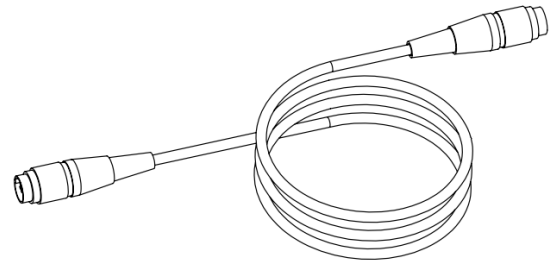

Pump Housing and Manifold Assembly

Part Number	Description
7509-1460	Pump Housing
7509-1150	Fluid Manifold, K-type Nozzle 1:1
3300-0656	GASKET, 1/2" ID X 5/8" X 1/16 W, VITON
7509-1190 3300-0662	Fluid Manifold, Plug Screws Plug Screw O-rings, 3mm ID x 1 mm CS, EPDM

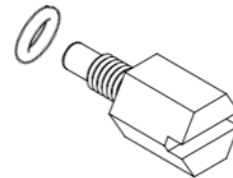

Stators

Part Number	Description
8100-100-002	100 Series
8100-200-002	200 Series
8100-300-002	300 Series



Output Port Adaptors

Part Number	Description
8200D-000-001	Calibration Adaptor Assembly Includes: -x1 7509-1210 Calibration Adaptor -x2 3300-0662 O-rings, 3mm x 1mm CS, EPDM -x2 2800-1030 Captive Screws
7509-1160	1:1/2:1 K-Type Nozzle Locking Plate
8200D-000-006	4:1/10:1 K-Type Nozzle Adaptor Includes: -x1 7509-1170 K-Type Nozzle Adaptor -x2 3300-0662 O-rings, 3mm x 1mm CS, EPDM -x2 2800-1033 Screws, M3 x 6mm, SHC, S.S



8200D-000-005	<p>Bayonet Adaptor Includes:</p> <ul style="list-style-type: none"> -x1 Bayonet Adaptor -x2 Screws, M3 x 10mm, SHC, S.S -x2 3300-0662 O-rings, 3mm x 1mm CS, EPDM
---------------	--



Syringe Bracket

Part Number	Description
TS8200D-SYBRACKET	<p>Syringe Bracket for Syringe Barrels</p> <p>Includes:</p> <ul style="list-style-type: none"> -x2 Syringe Holder, 30/55cc -x2 Syringe Holder adaptors, 10cc -x2 Syringe Holder adaptor, 6cc -x2 Syringe Holder adaptor, 3cc

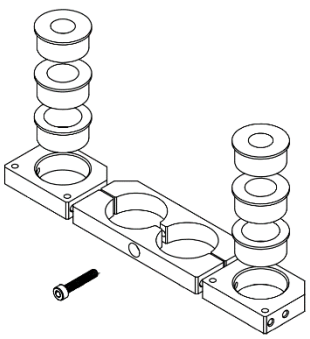

Mounting

Part Number	Description
2800-1031	Mounting Screws, M4 x 35MM, SHC, S.S
7506-0280	Mounting Bracket (for TSR robot)

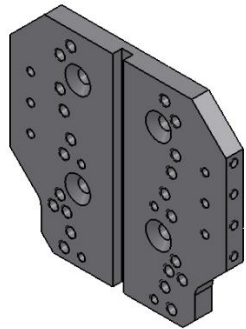

Cleaning Kits

Part Number	Description
8200D-CLEANKIT	<p>Cleaning Kit</p> <p>Includes:</p> <ul style="list-style-type: none">- x1 TSD2106-1, Cleaning Brush, Small, 0.15" (3.8mm)- x1 Cleaning Brush, Large, 0.45" (11.4mm)- x1 Wrench, Hex L-key, 1.5mm x 1-3/4"- x1 Wrench, Hex L-key, 2.0mm x 1-57/64"- x1 Wrench, Hex L-key, 1.3mm x 2-13/16"- x1 Wrench, Hex L-key, 3.0mm- x4 7509-0990, Shaft seals- x2 3300-0353, Cup Seals- x4 3300-0696, Vent Seal Washers

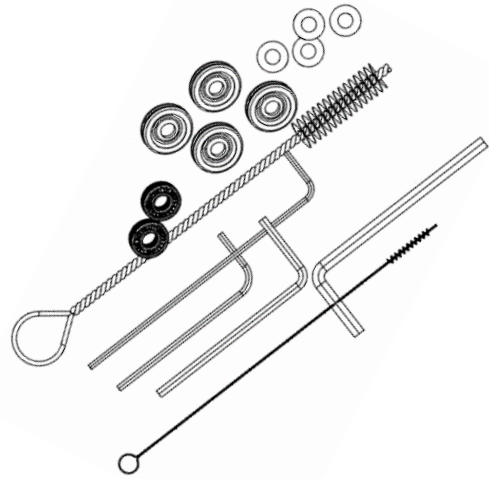

Optional Accessories

Part Number	Description
8200D-PS	Pressure Sensor



Part Number	Description
8200D-SEALKIT	<p>Seal Kit Includes:</p> <ul style="list-style-type: none"> - x2 Gasket, 1/2" ID X 5/8" X 1/16 W, VITON - 2x Cup Seal, UHMW, S.S.Spring, TS7000 - x4 Shaft Seal - x4 O-Ring, Square, 3/4" ID X 7/8" OD X 1/16 W, BUNA N - 4x Washer, #8-.15" ID X. 31" OD X .52 THK, Fluorosilicone
7305XCON	Cleaning Conditioner, 30cc





7. Troubleshooting

PROBLEM	POSSIBLE CAUSE	CORRECTION
No Fluid Flow	Dispense tip is clogged	Replace tip
	Motor does not receive signal	Make sure all connections are secured
	Motor running in reverse	Reverse motor cable connection
	Barrel of dispense fluid is empty	Replace with new fluid barrel
	Fluid feed pressure is too low	Increase feed pressure.
Inconsistent Shot size	Fluid dried or cured	Replace with new fresh fluid
	Fluid pressure fluctuating	Make sure fluid pressure is constant
	Valve on-time is too short	Increase valve on time
	Excessive motor reverse time	Reduce reverse time or turn off completely.
Inconsistent Shot size	Air trapped in fluid	Purge valve properly
Skipped dots	Intermittent motor signal	Check and replace motor
	Air trapped in fluid	De-air fluid
Fluids drools after valve is turned off	Air trapped in fluid chamber	Purge valve properly
	Air trapped in fluid reservoir	Remove air from reservoir



8. Appendix A

Pump Combination Selection Guide - Flow rates vs Ratio Table for different pump types

Ratio	Pump Types					
	100x100	200x200	300x300	200x100	300x100	300x200
1:1	0.28 - 2.80	1.26 - 12.6	1.54 - 15.40	1.26 - 2.80	1.54 - 2.80	1.54 - 12.6
2:1	0.42 - 2.10	1.89 - 9.45	2.31 - 11.5	0.95 - 4.20	1.16 - 4.20	1.90 - 11.5
4:1	0.70 - 1.75	3.15 - 7.87	3.85 - 9.62	0.79 - 7.00	0.97 - 7.00	3.15 - 9.63
6:1	0.98 - 1.63	4.41 - 7.35	5.39 - 9.00	1.00 - 7.35	1.00 - 9.00	4.41 - 9.00
8:1	1.26 - 1.57	5.67 - 7.01	6.93 - 8.66	1.26 - 7.10	1.26 - 8.67	5.67 - 8.66
10:1	1.54 - 1.54	6.93 - 6.93	8.47 - 8.47	1.54 - 6.93	1.54 - 8.50	6.93 - 8.50

Units = ml/min

*Flows are based on average calibration on a standard material similar to Vaseline and can vary by viscosity, density, and pump variation.



9. Limited Warranty & Contact Information

Manufacturer warrants this product to the original purchaser for a period of one (1) year from date of purchase to be free from defects in fluid and workmanship, but not against damages by misuse, negligence, accident, faulty installations, and instructions. Manufacturer will repair or replace (at factory's option), free of charge, any component of the equipment thus found to be defective, on return of the component, "PREPAID" to the factory during the warranty period. In no event shall any liability or obligation of the Manufacturer arising from this warranty exceed the purchase price of the equipment. This warranty is only valid if the defective product is returned as a complete assembly without physical damage. The Manufacturer's liability, as stated herein, cannot be altered or enlarged except by a written statement signed by an officer of the company. In no event shall the Manufacturer be liable for consequential or incidental damages. A return authorization is required from Techcon Systems prior to shipping a defective unit to the factory.

Manufacturer reserves the right to make engineering product modifications without notice.

All returns must be issued with a Returns Authorization number, prior to return. Send warranty returns to:

Americas

OK International
10800 Valley View Street
Cypress, CA 90630
United States

Asia

OK International
4th floor East, Electronic Building,
Yanxiang Industrial Zone, High Tech Road,
Guangming New District, Shenzhen P.R.C

Europe

OK International
Eagle Close
Chandler's Ford Ind Est
Eastleigh, Hampshire
SO53 4NF
United Kingdom

Delrin®, Viton® and Teflon® are registered trademarks of E.I. DuPont.